

PARTS CATALOGUE

YZ250V (1P85) U.S.A., CANADA

YZ250 (1P86) EUROPE

YZ250 (1P87) JAPAN

YZ250V (1P88) OCEANIA

YZ250 (1P88) SOUTH AFRICA



2005-12-19

1E1P8-100E1

(2E1P8-100E1)

NEWS NO.	DATE	COMMENT
PE0-MC-050192	Nov., 1, 2005	COR: YZ250/V(1P85/6/7/8) FRONT FORK/LIST/ILLUSTRATION CORRECTION

YZ250V/YZ250
PARTS CATALOGUE
©2005 by Yamaha Motor Co., Ltd.
1st edition, June 2005
All rights reserved.
Any reprinting or unauthorized use
without the written permission of
Yamaha Motor Co., Ltd.
is expressly prohibited.
Printed in Japan.

A3



A4

FOREWORD

This Parts Catalogue is related to the parts for the model(s) on the cover page. When you are ordering replacement parts, please refer to this Parts Catalogue and quote both part numbers and part names correctly.

1. Modifications or additions which have been made after the issue of the Parts Catalogue will be announced in the Parts News.

It is advisable that you make the necessary corrections to the Parts Catalogue according to the Parts News.

2. Abbreviations

The following abbreviations are used in this Parts Catalogue.

“UR” Use specified parts number.

“UN” Use as many as needed.

“AP” Alternate Parts

“LM” Locally Made (Parts need to be ordered locally)

“F#” Frame No. (Applicable machine No.)

“O/S” Over Size

3. The number of components for assembly

- Parts, which are to be supplied in an assembly, are listed with a dot (.) in front of the part name as shown below.
- The numeral appearing to the right of each component part indicates the quantity of parts for each assembly unit.

PART NO.	DESCRIPTION	Q'TY	REMARKS
2F5-83310-60	FRONT FLASHER LIGHT ASSY	2	
115-83311-60	.BULB (6V-18W)	1	

4. Applicable colours of graphics are represented in the “REMARKS” as shown below.

PART NO.	DESCRIPTION	Q'TY	REMARKS
2N4-24110-00-X5	FUEL TANK COMP.	2	MXR
3J1-24240-10	.GRAPHIC, FUEL TANK	1	FOR MXR

5. Note that the illustrations for reference in finding parts numbers are not to be used for assembling. When assembling, please use the applicable service manual.

6. The asterisk (*) before a reference number indicates modified items after the first edition.

FOREWORD

7. Applicable Serial No.

Engine Serial No.

Frame Serial No.

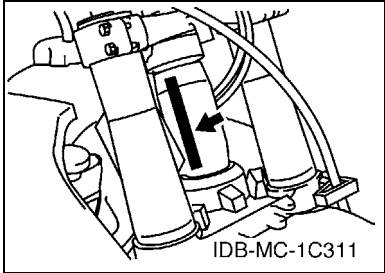
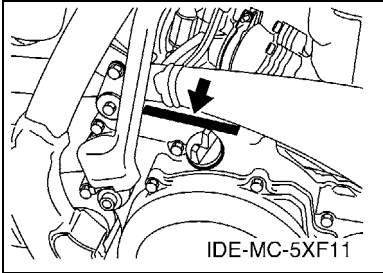

8. Applicable Colour Code (The (*) mark shows Model colour.)

Abbreviation	Colour Name	Colour Code
DPBSE(*)	DEEP PURPLISH BLUE SOLID E	0583

MODEL LABEL

(1) A label called “Model Label” is affixed in the location as indicated in (3) below.
When using this parts catalogue, please be sure to cross-reference the “model code – production code No.” in the catalogue with the “model code – production code No.” indicated on the Model Label affixed onto the product concerned.

(2) “Model Label” Indication

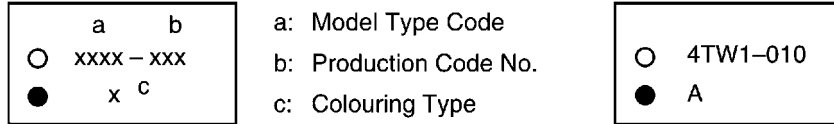

(3) Model Label Affixing Location

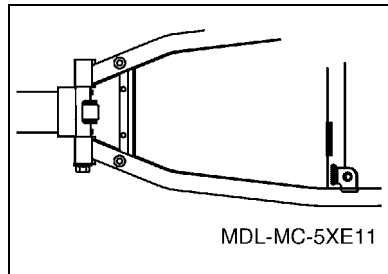

(4) Colouring Information

Model Code	Colouring Type Code	Colour Code	Colour Name	Abbreviation
1P85	A	0583	DEEP PURPLISH BLUE SOLID E	DPBSE
1P86	A	0583	DEEP PURPLISH BLUE SOLID E	DPBSE
1P87	A	0583	DEEP PURPLISH BLUE SOLID E	DPBSE
1P88	A	0583	DEEP PURPLISH BLUE SOLID E	DPBSE

(5) Model Code – Production Code Number of Model Listed in This Parts Catalogue

Model Code	Production Code No.	Country (destination)	Model Code	Production Code No.	Country (destination)
1P85	010	U.S.A.			
	020	CANADA			
1P86	010	EUROPE			
1P87	010	JAPAN			
1P88	010	AUSTRALIA			
		NEW ZEALAND			
	030	SOUTH AFRICA			

CONTENTS

ENGINE

CYLINDER HEAD	B2
GOVERNOR	B4
CRANKSHAFT & PISTON	B5
WATER PUMP	B6
RADIATOR & HOSE	B7
INTAKE	B8
CARBURETOR	B9
EXHAUST	B13
CRANKCASE	B15
CRANKCASE COVER 1	C2
STARTER	C3
CLUTCH	C4
TRANSMISSION	C6
SHIFT CAM & FORK	C8
SHIFT SHAFT	C9

CHASSIS

FRAME	C10
FENDER	C12
SIDE COVER	C14
REAR ARM	C15
REAR SUSPENSION	D3
STEERING	D5
FRONT FORK	D6
FUEL TANK	D9
SEAT	D11
FRONT WHEEL	D12
FRONT BRAKE CALIPER	D13
REAR WHEEL	D14
REAR BRAKE CALIPER	E2
STEERING HANDLE & CABLE	E3
FRONT MASTER CYLINDER	E4
STAND & FOOTREST	E5
REAR MASTER CYLINDER	E6
GENERATOR	E7
HANDLE SWITCH & LEVER	E8
ELECTRICAL 1	E9
ALTERNATE FOR CHASSIS	E10
OPTIONAL PARTS 1	E11

INDEX

NUMERICAL INDEX	M1
-----------------------	----

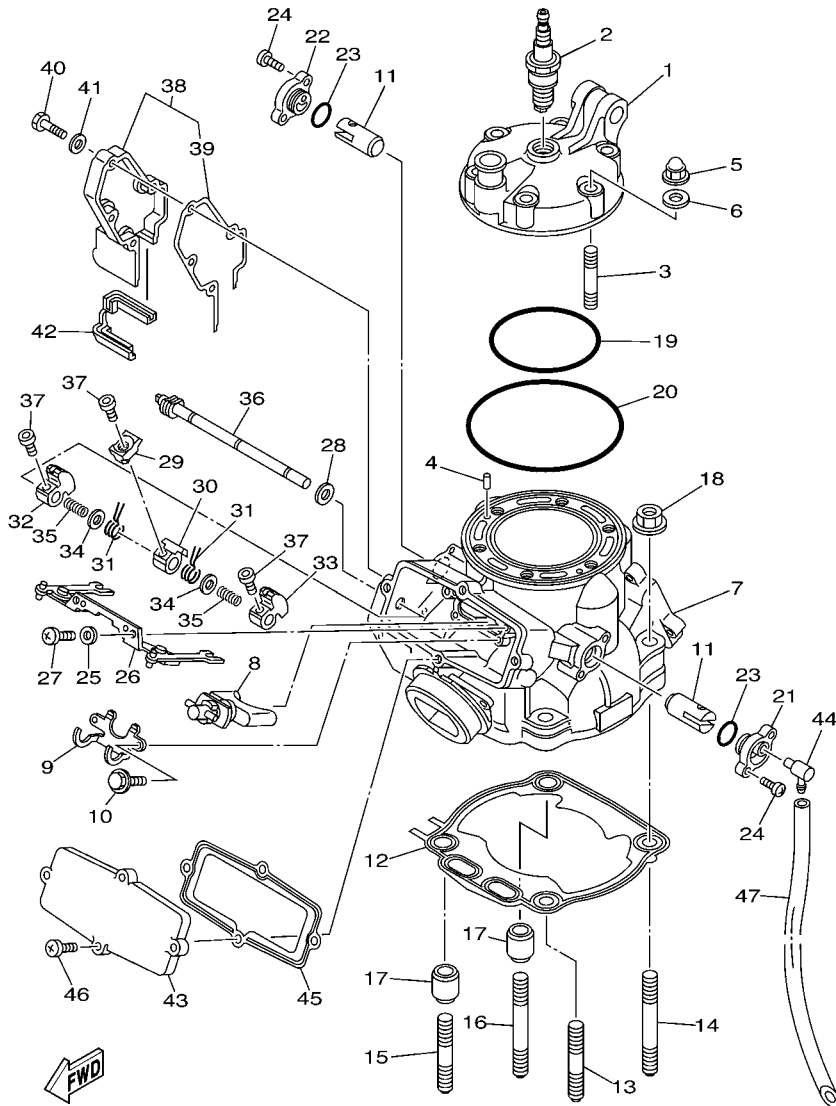

5NX1100-A010

FIG. 1 CYLINDER HEAD

REF. NO.	PART NO.	DESCRIPTION	1P85	1P86	1P87	1P88	REMARKS
1	5UP-11111-00	HEAD, CYLINDER 1	1				
	5MW-11111-01	HEAD, CYLINDER 1		1	1	1	
2	94702-00326	PLUG, SPARK (NGK BR8EG)	1	1		1	
	94709-00326	PLUG, SPARK (NGK BR8EG)			1		
3	90116-08394	BOLT, STUD	6	6	6	6	
4	93604-08071	PIN, DOWEL	2	2	2	2	
5	90176-08026	NUT, CROWN	6	6	6	6	
6	90201-080L8	WASHER, PLATE	6	6	6	6	
7	5UP-11311-01	CYLINDER 1	1	1	1	1	
8	5XF-1131D-00	VALVE ASSY	1	1	1	1	
9	5CU-1131U-10	HOLDER 3	1	1	1	1	
10	90109-05001	BOLT	2	2	2	2	
11	5CU-1132A-00	VALVE 2	2	2	2	2	
12	5UP-11351-00	GASKET, CYLINDER	1	1	1	1	
13	90116-10314	BOLT, STUD	1	1	1	1	
14	95617-10660	BOLT, STUD	1	1	1	1	
15	90116-10314	BOLT, STUD	1	1	1	1	
16	95617-10660	BOLT, STUD	1	1	1	1	
17	99590-14016	PIN, DOWEL	2	2	2	2	
18	90179-10M35	NUT	4	4	4	4	
19	93210-74316	O-RING	1	1	1	1	
20	93211-02703	O-RING	1	1	1	1	
21	5CU-1131E-01	HOLDER 1	1	1	1	1	
22	5CU-1131P-00	HOLDER 4	1	1	1	1	
23	93210-15639	O-RING	2	2	2	2	
24	98507-05012	SCREW, PAN HEAD	4	4	4	4	
25	90201-057H5	WASHER, PLATE	2	2	2	2	

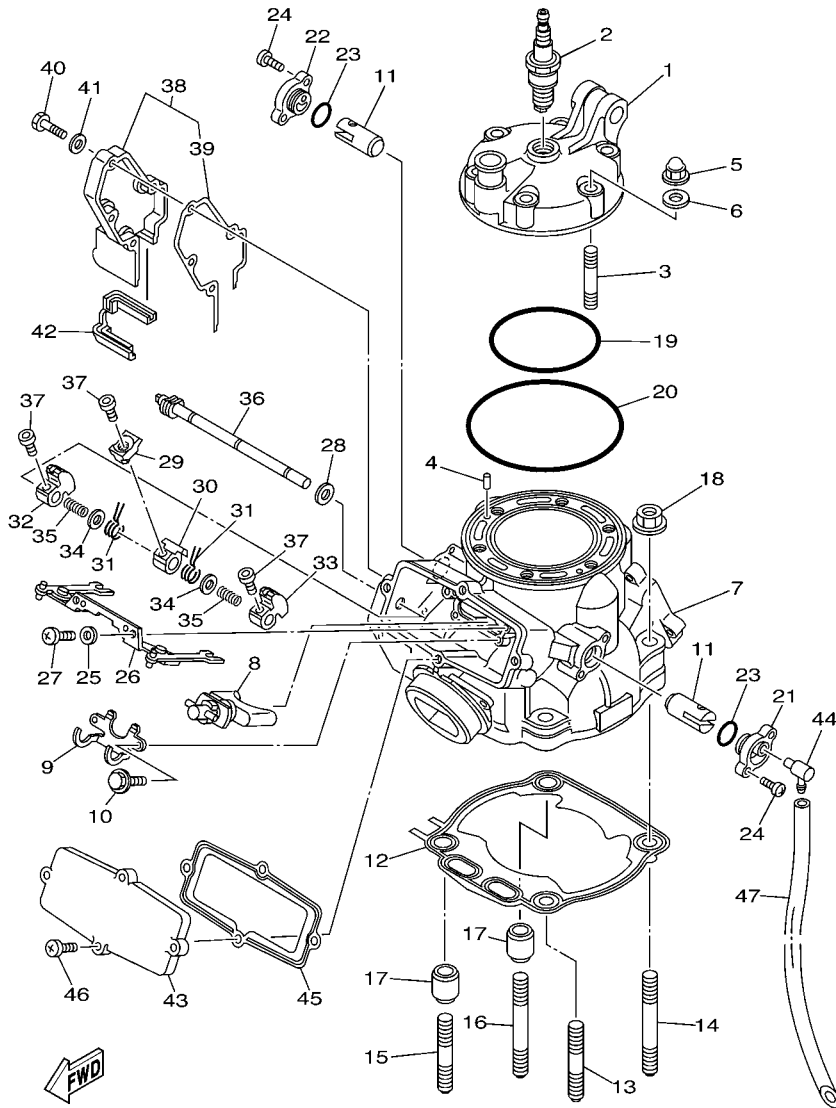

5NX1100-A010

FIG. 1 CYLINDER HEAD

REF. NO.	PART NO.	DESCRIPTION	1P85	1P86	1P87	1P88	REMARKS
26	5CU-11830-00	LINK ASSY	1	1	1	1	
27	98902-05012	SCREW, BIND	2	2	2	2	
28	93104-08040	OIL SEAL	1	1	1	1	
29	5NX-11395-00	HOLDER	1	1	1	1	
30	4SS-11832-00	LEVER, LINK	1	1	1	1	
31	90508-155B8	SPRING, TORSION	2	2	2	2	
32	5MW-1132E-00	PULLEY 1	1	1	1	1	
33	5MW-1132F-00	PULLEY 2	1	1	1	1	
34	90201-081G0	WASHER, PLATE	2	2	2	2	
35	90501-046L6	SPRING, COMPRESSION	2	2	2	2	
36	5CU-1131V-00	SHAFT 1	1	1	1	1	
37	91317-04008	BOLT	3	3	3	3	
38	5CU-11991-00	HOUSING 1	1	1	1	1	
39	5CU-11993-00	.GASKET	1	1	1	1	
40	97007-05020	BOLT	4	4	4	4	
41	92907-05600	WASHER, PLATE	4	4	4	4	
42	5CU-11995-00	SEAL, HOUSING	1	1	1	1	
43	5CU-1131M-10	COVER	1	1	1	1	
44	353-13115-01	CONNECTOR, SUCTION PIPE	1	1	1	1	
45	5CU-11354-00	GASKET	1	1	1	1	
46	98907-05016	SCREW, BIND	4	4	4	4	
47	90445-09777	HOSE (L300)	1	1	1	1	

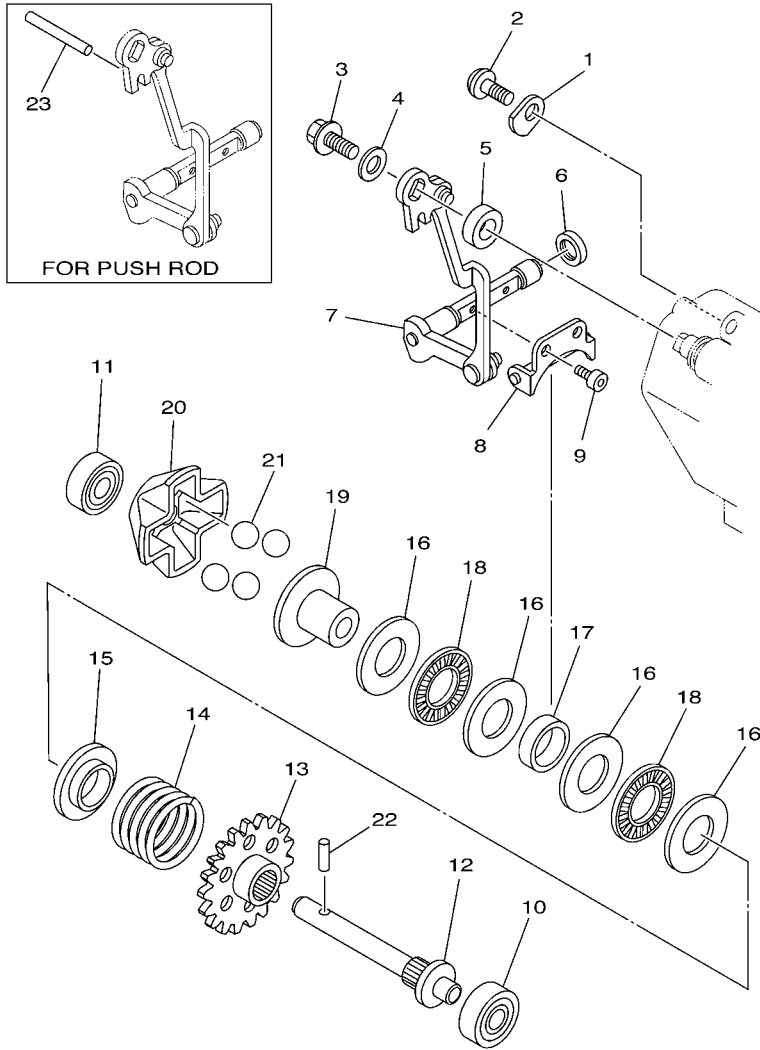

5NX1100-A020

FIG. 2 GOVERNOR

REF. NO.	PART NO.	DESCRIPTION	1P85	1P86	1P87	1P88	REMARKS
1	4JY-11915-10	PLATE, THRUST 1	1	1	1	1	
2	98902-05012	SCREW, BIND	1	1	1	1	
3	90105-05002	BOLT, FLANGE	1	1	1	1	
4	90201-057H5	WASHER, PLATE	1	1	1	1	
5	90387-085E1	COLLAR	1	1	1	1	
6	93104-08040	OIL SEAL	1	1	1	1	
7	5CU-11990-10	PUSH ROD ASSY	1	1	1	1	
8	3JE-11922-01	FORK, GOVERNOR	1	1	1	1	
9	91317-04006	BOLT	2	2	2	2	
10	93300-60801	BEARING	1	1	1	1	KOYO
11	93300-60801	BEARING	1	1	1	1	KOYO
12	5X4-11921-02	SHAFT, GOVERNOR	1	1	1	1	
13	5NY-11953-00	GEAR, GOVERNOR	1	1	1	1	
14	90501-256L2	SPRING, COMPRESSION	1	1	1	1	
15	5CU-11952-00	PLATE	1	1	1	1	
16	90201-150U6	WASHER, PLATE	4	4	4	4	
17	90387-152F2	COLLAR	1	1	1	1	
18	93340-21505	BEARING	2	2	2	2	
19	5CU-11912-00	RETAINER, WEIGHT	1	1	1	1	
20	5CU-11911-00	RETAINER	1	1	1	1	
21	93507-16020	BALL	4	4	4	4	
22	93603-14240	PIN, DOWEL	1	1	1	1	
23	93604-29184	PIN, DOWEL	1	1	1	1	AP

FIG. 3 CRANKSHAFT & PISTON

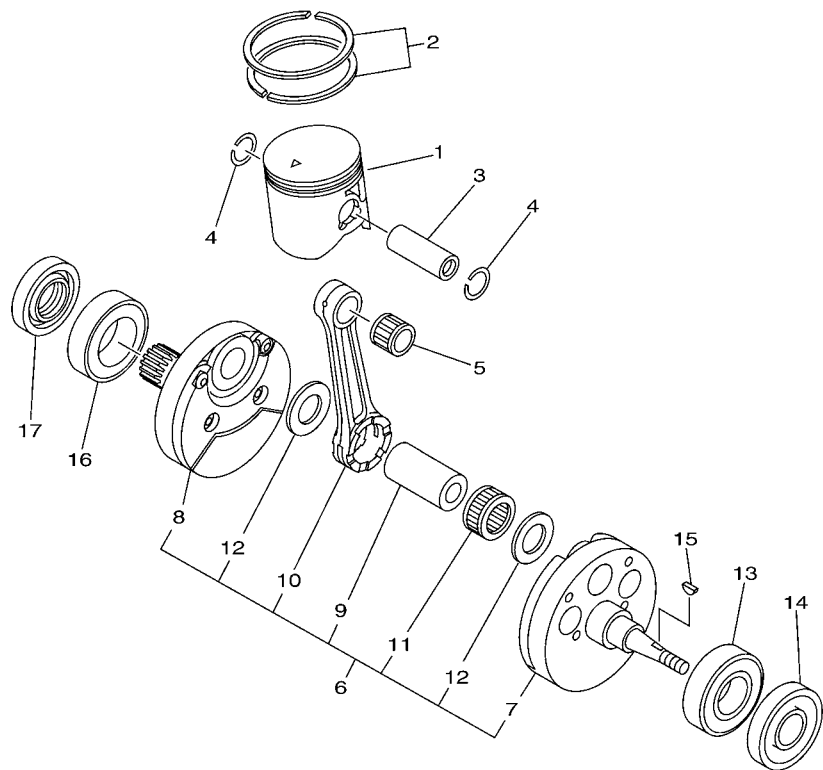

REF. NO.	PART NO.	DESCRIPTION	1P85	1P86	1P87	1P88	REMARKS
1	1P8-11631-00-A0	PISTON (STD)	1	1	1	1	UR RED
	1P8-11631-00-B0	PISTON (STD)	1	1	1	1	UR ORANGE
	1P8-11631-00-C0	PISTON (STD)	1	1	1	1	UR GREEN
	1P8-11631-00-D0	PISTON (STD)	1	1	1	1	UR PURPLE
2	5CU-11603-10	PISTON RING SET (STD)	1	1	1	1	
3	5UP-11633-00	PIN, PISTON	1	1	1	1	
4	93450-19052	CIRCLIP	2	2	2	2	
5	93310-218A6	BEARING	1	1	1	1	
6	5UP-11400-00	CRANKSHAFT ASSY	1	1	1	1	
7	5UP-11410-00	.CRANKSHAFT	1	1	1	1	
8	5MW-11420-00	.CRANKSHAFT	1	1	1	1	
9	5CU-11681-00	.PIN, CRANK 1	1	1	1	1	
10	5MW-11651-00	.ROD, CONNECTING	1	1	1	1	
11	93310-52406	.BEARING	1	1	1	1	
12	90209-24327	.WASHER	2	2	2	2	
13	93306-37808	BEARING	1	1	1	1	
14	93102-20485	OIL SEAL	1	1	1	1	
15	90280-03017	KEY, WOODRUFF	1	1	1	1	
16	93306-37808	BEARING	1	1	1	1	
17	93102-28004	OIL SEAL	1	1	1	1	



5MW1100-1030

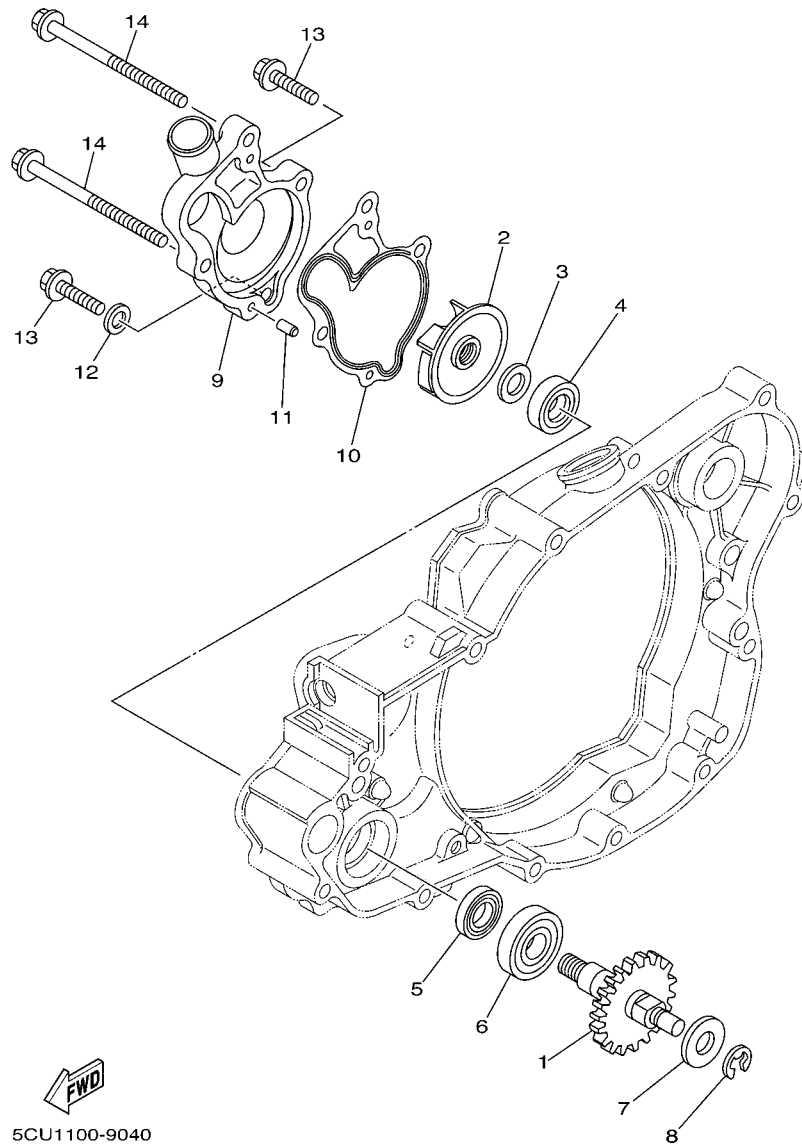
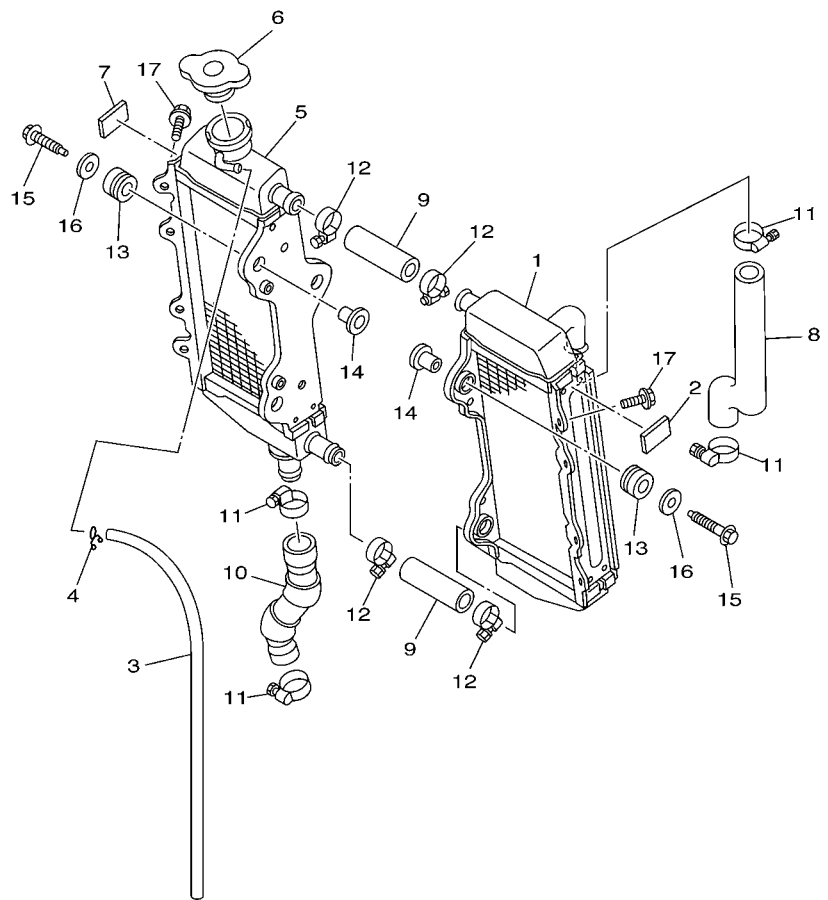

FIG. 4 WATER PUMP

REF. NO.	PART NO.	DESCRIPTION	1P85	1P86	1P87	1P88	REMARKS
1	5CU-12459-00	GEAR, IMPELLER SHAFT	1	1	1	1	
2	5DJ-12451-00	IMPELLER, WATER PUMP	1	1	1	1	
3	90201-08512	WASHER, PLATE	1	1	1	1	
4	93109-11073	OIL SEAL	1	1	1	1	
5	93102-12106	OIL SEAL (SD 12-22-5 HS)	1	1	1	1	
6	93306-00105	BEARING	1	1	1	1	
7	90201-08784	WASHER, PLATE	1	1	1	1	
8	99001-06600	CIRCLIP	1	1	1	1	
9	5MW-12422-00	COVER, HOUSING	1	1	1	1	
10	5XF-12428-00	GASKET, HOUSING COVER 2	1	1	1	1	
11	93604-10011	PIN, DOWEL	2	2	2	2	
12	90430-06014	GASKET	1	1	1	1	
13	95027-06025	BOLT, FLANGE	2	2	2	2	
14	95027-06065	BOLT, FLANGE	2	2	2	2	

FIG. 5 RADIATOR & HOSE



1P81100-D050

REF. NO.	PART NO.	DESCRIPTION	1P85	1P86	1P87	1P88	REMARKS
1	5NX-1240A-00	RADIATOR ASSY	1	1	1	1	
2	1C3-12465-00	DAMPER, RADIATOR	1	1	1	1	
3	91A20-05065	TUBE, FLEXIBLE VINYL	1	1	1	1	
4	90467-090A2	CLIP	1	1	1	1	
5	5NX-12461-00	RADIATOR ASSY	1	1	1	1	
6	22W-12462-00	CAP, RADIATOR	1	1	1	1	
7	1C3-12465-00	DAMPER, RADIATOR	1	1	1	1	
8	5CU-12481-10	PIPE 1	1	1	1	1	
9	5NY-12482-00	PIPE 2	2	2	2	2	
10	1P8-12484-00	PIPE 4	1	1	1	1	
11	90450-28001	HOSE CLAMP ASSY	4	4	4	4	
12	90450-25001	HOSE CLAMP ASSY	4	4	4	4	
13	90480-15528	GROMMET	6	6	6	6	
14	90387-06065	COLLAR	6	6	6	6	
15	95027-06030	BOLT, FLANGE	6	6	6	6	
16	90201-06571	WASHER, PLATE	6	6	6	6	
17	95822-06010	BOLT, FLANGE	2	2	2	2	

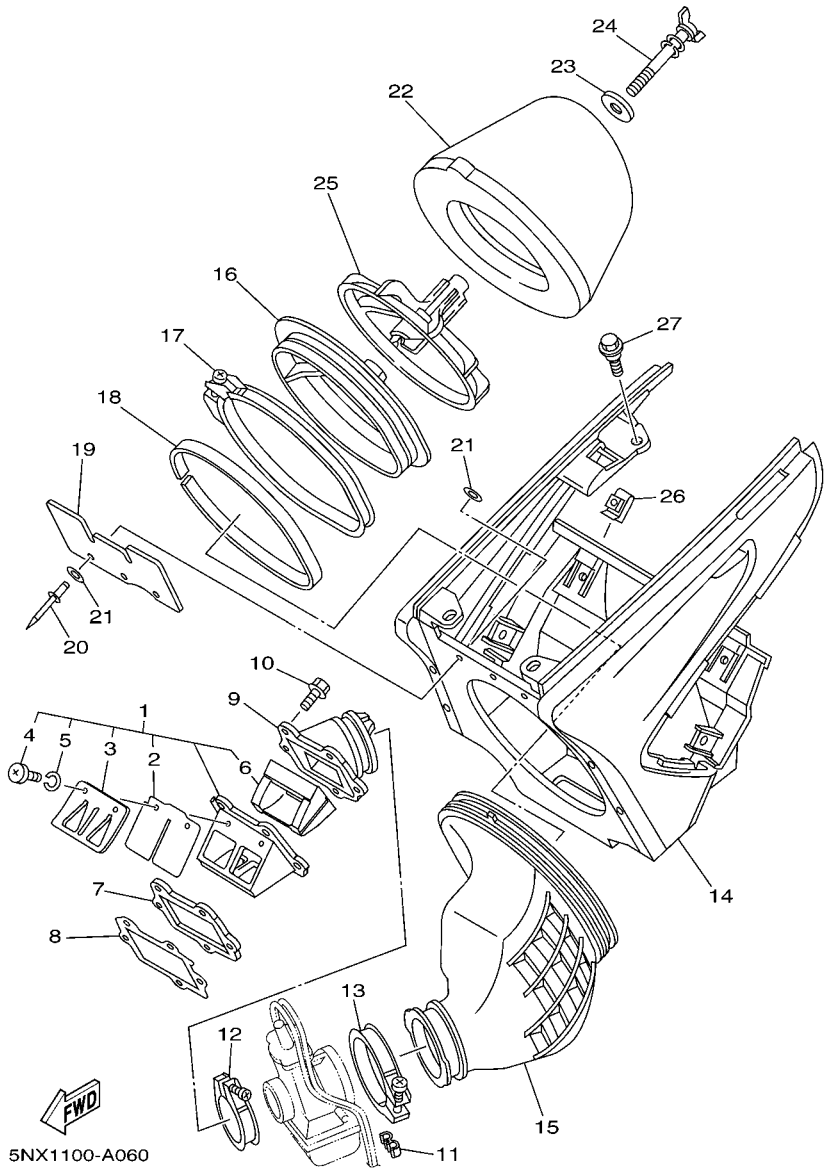
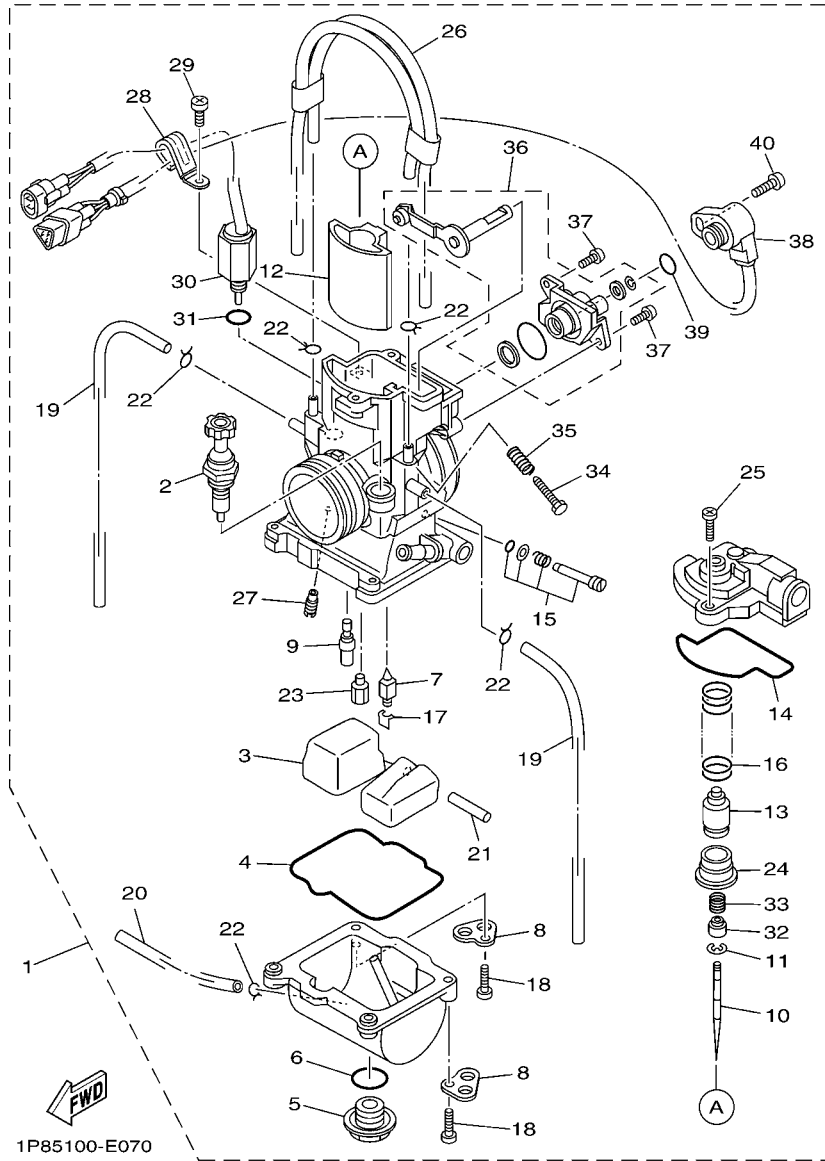

FIG. 6 INTAKE

REF. NO.	PART NO.	DESCRIPTION	1P85	1P86	1P87	1P88	REMARKS
1	5NX-13610-00	REED VALVE ASSY	1	1	1	1	
2	5NX-13613-00	.REED, VALVE	2	2	2	2	
3	4XL-13616-00	.STOPPER, REED VALVE	2	2	2	2	
4	98507-03008	.SCREW, PAN HEAD	4	4	4	4	
5	92907-03100	.WASHER, SPRING	4	4	4	4	
6	4XL-13625-00	.SPACER, REED VALVE	1	1	1	1	
7	5NX-13624-00	PLATE, REED VALVE	1	1	1	1	
8	5XF-13622-00	GASKET, VALVE SEAT	1	1	1	1	
9	5NX-13565-00	JOINT, CARBURETOR	1	1	1	1	
10	91317-06025	BOLT	5	5	5	5	
11	90464-06214	CLAMP	2	2	2	2	
12	90450-51070	HOSE CLAMP ASSY	1	1	1	1	
13	90450-70072	HOSE CLAMP ASSY	1	1	1	1	
14	5NY-14401-01	AIR CLEANER CASE ASSY	1	1	1	1	
15	5NX-14453-00	JOINT, AIR CLEANER 1	1	1	1	1	
16	5NY-14459-00	HOLDER, GUIDE	1	1	1	1	
17	5NY-14455-10	BAND	1	1	1	1	
18	5NY-14442-00	SPACER	1	1	1	1	
19	5NY-14417-00	COVER 1	1	1	1	1	
20	90267-32070	RIVET, BLIND	3	3	3	3	
21	90201-03313	WASHER, PLATE	6	6	6	6	
22	4XM-14451-00	ELEMENT, AIR CLEANER	1	1	1	1	
23	90209-06096	WASHER	1	1	1	1	
24	90122-06005	BOLT, WING	1	1	1	1	
25	3JD-14458-01	GUIDE	1	1	1	1	
26	90183-06023	NUT, SPRING	4	4	4	4	
27	90109-067F4	BOLT	4	4	4	4	



1P85100-E070

FIG. 7 CARBURETOR

REF. NO.	PART NO.	DESCRIPTION	1P85	1P86	1P87	1P88	REMARKS
1	1P8-14101-30	CARBURETOR ASSY 1	1				
	1P8-14101-40	CARBURETOR ASSY 1		1			
	1P8-14101-50	CARBURETOR ASSY 1			1	1	
2	4JT-14171-00	.PLUNGER, STARTER	1	1	1	1	
3	4SR-14985-00	.FLOAT	1	1	1	1	
4	4JT-14984-00	.GASKET, FLOAT CHAMBER	1	1	1	1	
5	4MX-14115-00	.PLUG, SCREW	1	1	1	1	
6	4MX-14561-00	.O-RING	1	1	1	1	
7	4MX-14392-00	.VALVE, NEEDLE	1	1	1	1	
8	4XL-14146-00	.PLATE	2	2	2	2	
9	4MX-14948-07	.JET, SLOW (#50)	1		1	1	STD
	4MX-14948-08	.JET, SLOW (#52)		1			STD
	4MX-14948-02	.JET, SLOW (#38)	1	1	1	1	AP
	4MX-14948-03	.JET, SLOW (#40)	1	1	1	1	AP
	4MX-14948-04	.JET, SLOW (#42)	1	1	1	1	AP
	4MX-14948-05	.JET, SLOW (#45)	1	1	1	1	AP
	4MX-14948-06	.JET, SLOW (#48)	1	1	1	1	AP
	4MX-14948-07	.JET, SLOW (#50)		1			AP
	4MX-14948-08	.JET, SLOW (#52)	1		1	1	AP
	4MX-14948-09	.JET, SLOW (#55)	1	1	1	1	AP
	4MX-14948-10	.JET, SLOW (#58)	1	1	1	1	AP
	4MX-14948-11	.JET, SLOW (#60)	1	1	1	1	AP
	4MX-14948-12	.JET, SLOW (#62)	1	1	1	1	AP
10	4SR-14916-EJ	.NEEDLE (N3EJ)	1				STD
	4SR-14916-EW	.NEEDLE (N3EW)		1	1	1	STD
	4SR-14916-CK	.NEEDLE (N3CK)	1				AP
	4SR-14916-EK	.NEEDLE (N3EK)	1				AP

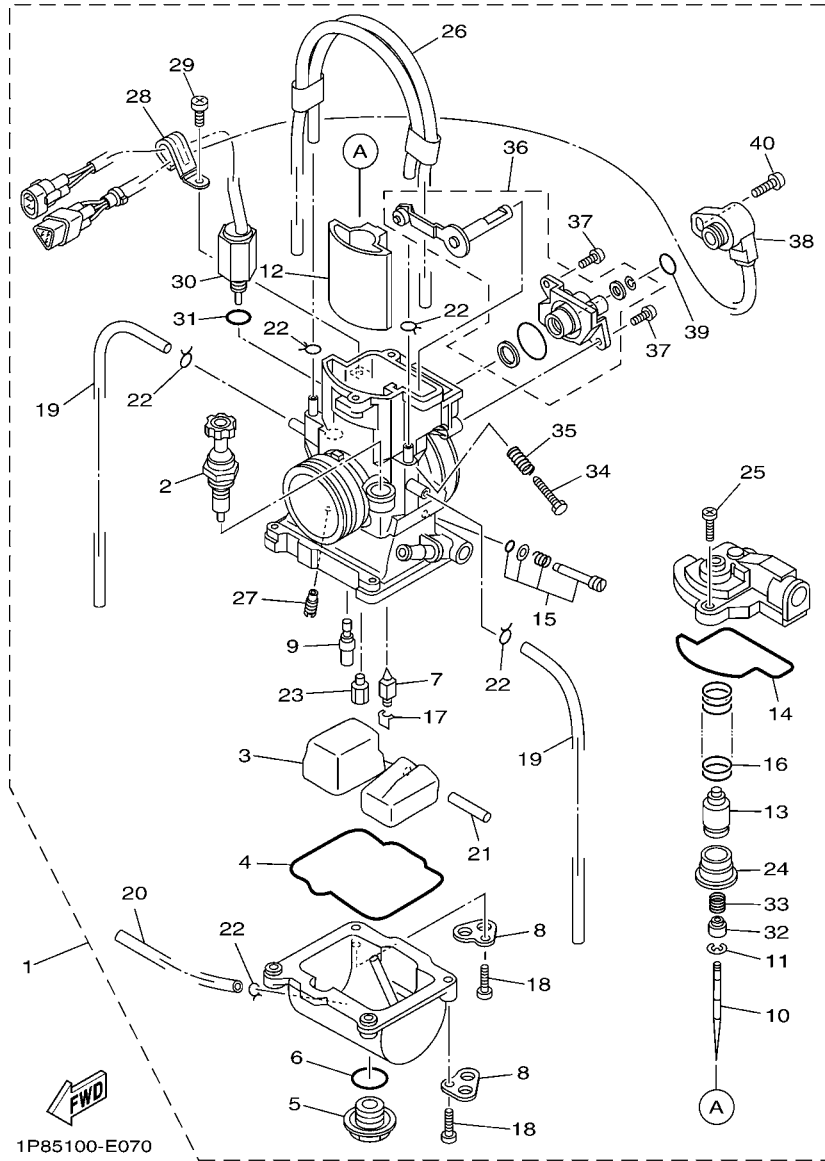

1P85100-E070

FIG. 7 CARBURETOR

REF. NO.	PART NO.	DESCRIPTION	1P85	1P86	1P87	1P88	REMARKS
10	4SR-14916-CW	.NEEDLE (N3CW)		1	1	1	AP
	4SR-14916-CJ	.NEEDLE (N3CJ)	1	1	1	1	AP
	4SR-14916-EJ	.NEEDLE (N3EJ)		1	1	1	AP
	4SR-14916-RJ	.NEEDLE (N8RJ)	1				AP
	4SR-14916-EW	.NEEDLE (N3EW)	1				AP
	4SR-14916-RW	.NEEDLE (N8RW)	1	1	1	1	AP
	4SR-14916-EH	.NEEDLE (N3EH)		1	1	1	AP
	4SR-14916-RH	.NEEDLE (N8RH)		1	1	1	AP
11	4MX-14919-00	.CLIP	1	1	1	1	
12	5HC-14340-A7	.VALVE ASSY	1	1	1	1	
13	5HC-14261-00	.HOLDER	1	1	1	1	
14	5HC-14126-00	.GASKET	1	1	1	1	
15	4SR-14105-00	.PILOT SCREW SET	1	1	1	1	
16	5HC-14131-00	.SPRING, THROTTLE VALVE	1	1	1	1	
17	663-14159-00	.CLIP	1	1	1	1	
18	98502-04014	.SCREW, PAN HEAD	4	4	4	4	
19	4XL-14197-10	.PIPE	2	2	2	2	
20	4XL-14196-10	.PIPE	1	1	1	1	
21	676-14548-00	.PIN, FLOAT ARM	1	1	1	1	
22	3TJ-14137-40	.CLIP	5	5	5	5	
23	4MX-14943-93	.JET, MAIN (#178)	1		1	1	STD
	4MX-14943-43	.JET, MAIN (#180)		1			STD
	4MX-14943-90	.JET, MAIN (#162)	1	1	1	1	AP
	4MX-14943-40	.JET, MAIN (#165)	1	1	1	1	AP
	4MX-14943-91	.JET, MAIN (#168)	1	1	1	1	AP
	4MX-14943-41	.JET, MAIN (#170)	1	1	1	1	AP
	4MX-14943-92	.JET, MAIN (#172)	1	1	1	1	AP

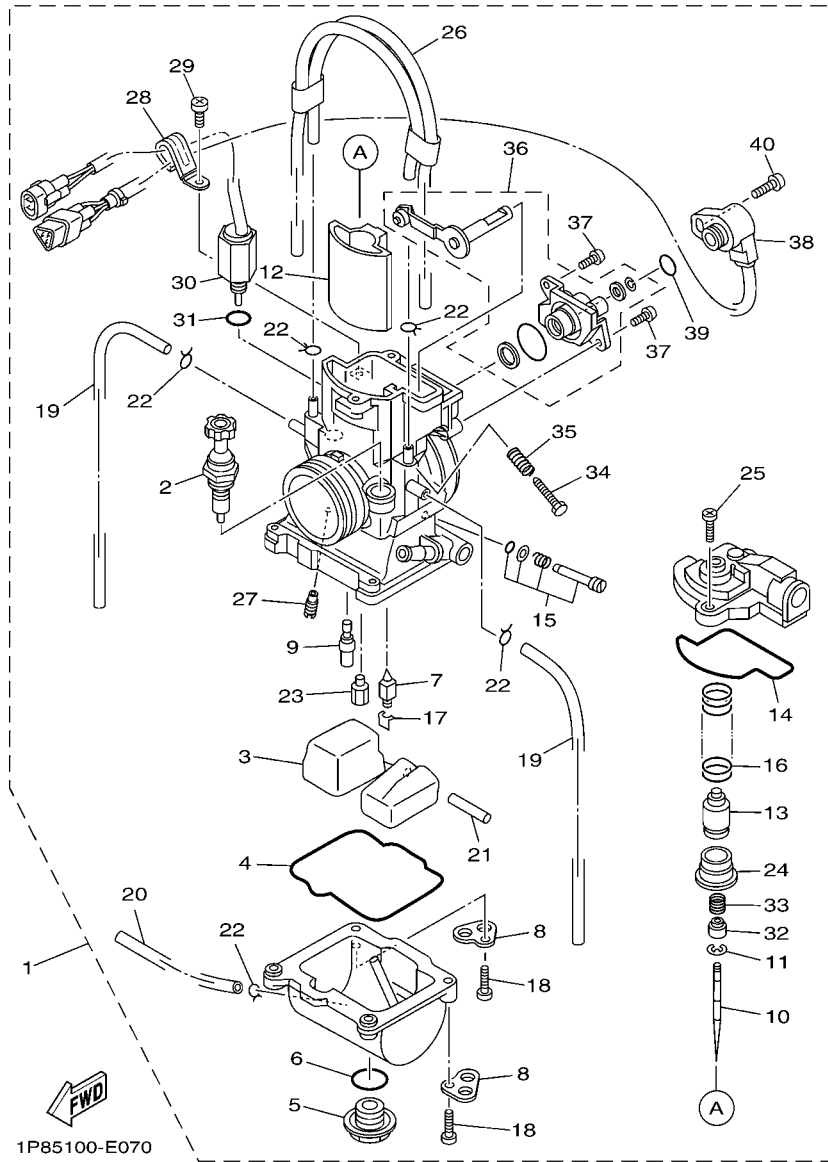

1P85100-E070

FIG. 7 CARBURETOR

REF. NO.	PART NO.	DESCRIPTION	1P85	1P86	1P87	1P88	REMARKS
23	4MX-14943-42	.JET, MAIN (#175)	1	1	1	1	AP
	4MX-14943-93	.JET, MAIN (#178)		1			AP
	4MX-14943-43	.JET, MAIN (#180)	1		1	1	AP
	4MX-14943-94	.JET, MAIN (#182)	1	1	1	1	AP
	4MX-14943-44	.JET, MAIN (#185)	1	1	1	1	AP
	4MX-14943-95	.JET, MAIN (#188)	1	1	1	1	AP
	4MX-14943-45	.JET, MAIN (#190)	1	1	1	1	AP
24	4MX-14194-00	.RING	1	1	1	1	
25	98502-04012	.SCREW, PAN HEAD	2	2	2	2	
26	4XL-1410E-00	.HOSE	1	1	1	1	
27	4JT-1494F-07	.JET (#50)	1	1	1	1	STD
	4JT-1494F-03	.JET (#40)	1	1	1	1	AP
	4JT-1494F-09	.JET (#55)	1	1	1	1	AP
	4JT-1494F-11	.JET (#60)	1	1	1	1	AP
	4JT-1494F-13	.JET (#65)	1	1	1	1	AP
28	5HC-14146-00	.PLATE	1	1	1	1	
29	98580-04006	.SCREW, PAN HEAD	1	1	1	1	
30	5NX-1410H-10	.FUEL CUT SOLENOID VALVE	1	1	1	1	
31	4JT-14147-00	.O-RING	1	1	1	1	
32	5HC-14264-00	.COLLAR	1	1	1	1	
33	5HC-14275-00	.SPRING	1	1	1	1	
34	5HC-14922-00	.SCREW, THROTTLE	1	1	1	1	
35	5HC-14934-00	.SPRING, THROTTLE STOP	1	1	1	1	
36	1P8-14208-00	.LEVER COMP. 1	1	1	1	1	
37	5HC-14216-00	.SCREW	2	2	2	2	
38	5NX-85885-10	.THROTTLE SENSOR ASSY	1	1	1	1	
39	5NX-14562-00	.O-RING	1	1	1	1	

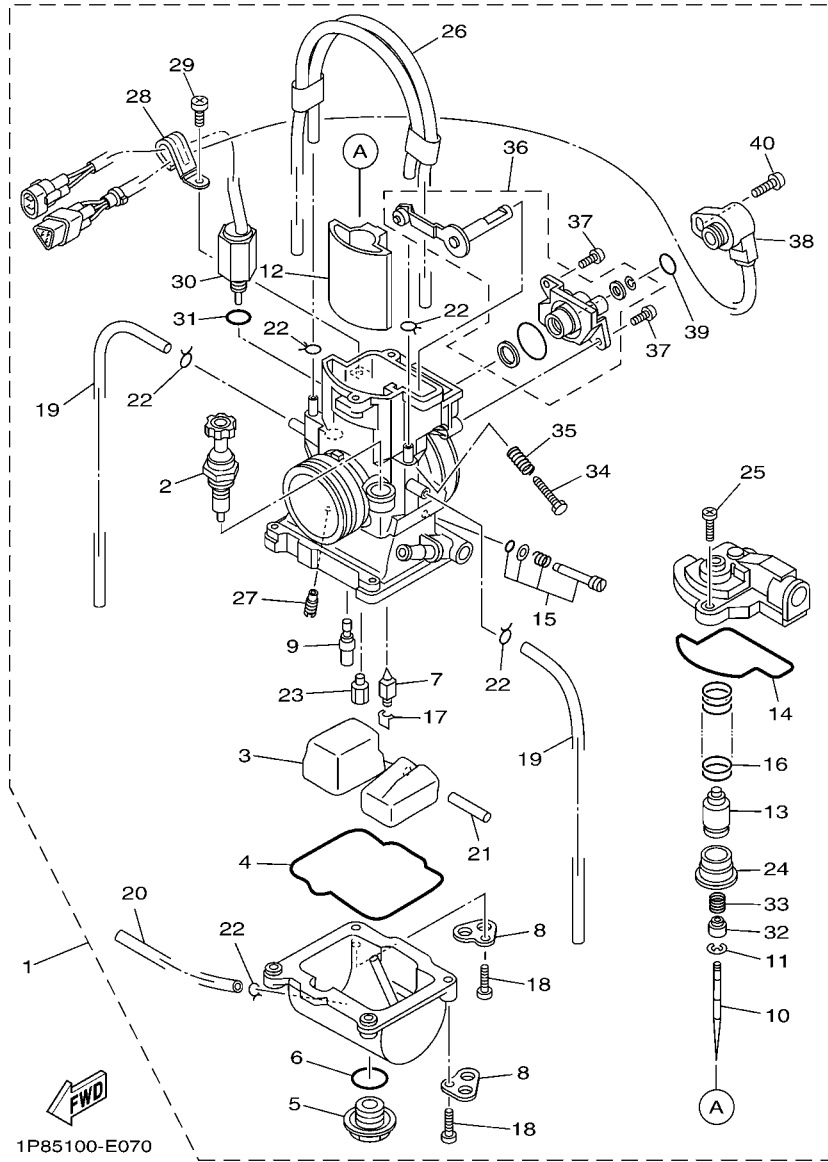

1P85100-E070

FIG. 7 CARBURETOR

REF. NO.	PART NO.	DESCRIPTION	1P85	1P86	1P87	1P88	REMARKS
40	5NX-14216-00	.SCREW	1	1	1	1	

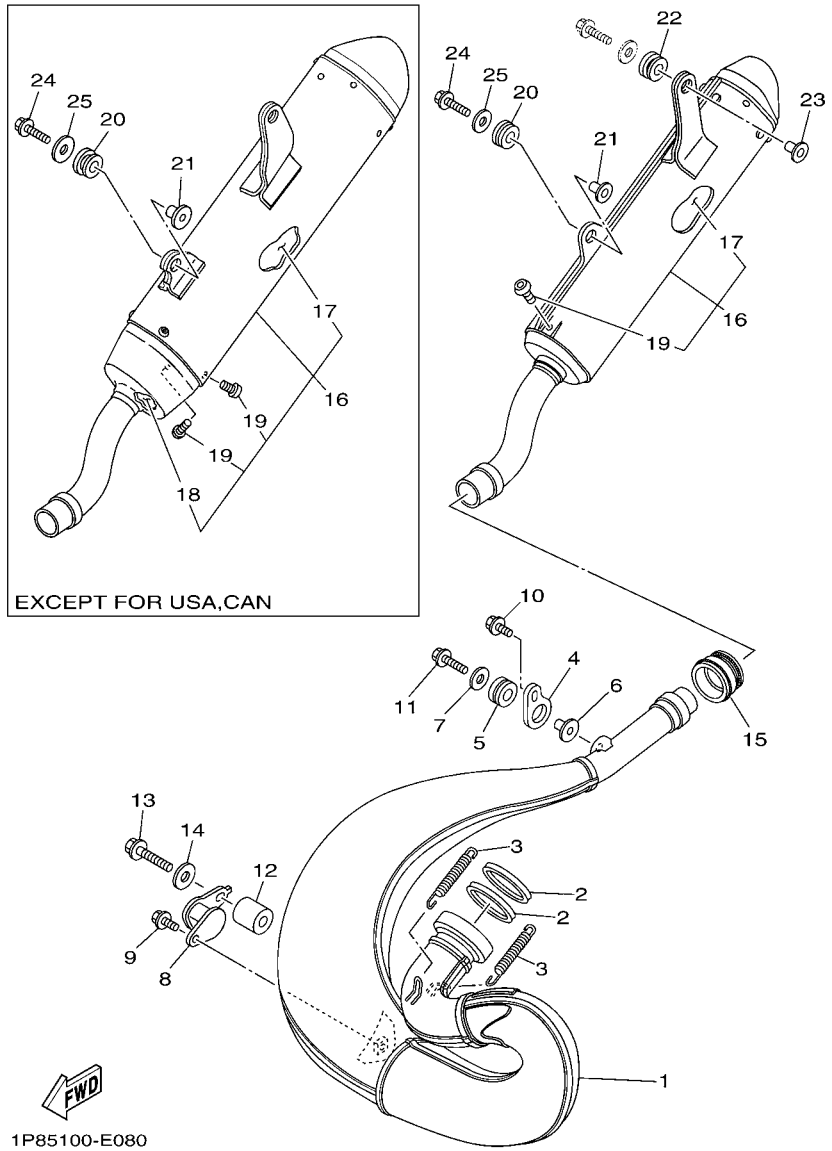

1P85100-E080

FIG. 8 EXHAUST

REF. NO.	PART NO.	DESCRIPTION	1P85	1P86	1P87	1P88	REMARKS
1	1P8-14610-00	EXHAUST PIPE ASSY 1	1		1	1	
	1P8-14610-10	EXHAUST PIPE ASSY 1		1			
2	5MW-14642-00	SEAL, EXHAUST	2	2	2	2	
3	90507-20052	SPRING, TENSION	2	2	2	2	
4	5CU-14771-01	STAY, MUFFLER 1	1	1	1	1	
5	90480-16561	GROMMET	1	1	1	1	
6	90387-063G3	COLLAR	1	1	1	1	
7	90201-06033	WASHER, PLATE	1	1	1	1	
8	5XF-14781-00	STAY, MUFFLER 2	1	1	1	1	
9	90119-06133	BOLT, WITH WASHER	1	1	1	1	
10	90119-06133	BOLT, WITH WASHER	1	1	1	1	
11	95022-06025	BOLT, FLANGE	1	1	1	1	
12	90387-08030	COLLAR	1	1	1	1	
13	95022-08035	BOLT, FLANGE	1	1	1	1	
14	90201-08049	WASHER, PLATE	1	1	1	1	
15	3JE-14615-01	JOINT, EXHAUST 1	1	1	1	1	
16	5NX-14753-11	SILENCER, EXHAUST	1				
	1P8-14753-00	SILENCER, EXHAUST		1	1	1	
17	5HC-1469A-10	.FIBER	1				
	1P8-1469A-00	.FIBER		1	1	1	
18	1P8-1469E-00	.FIBER		1	1	1	
19	92017-06010	.BOLT, BUTTON HEAD	2				
	92012-06010	.BOLT, BUTTON HEAD		4	4	4	
20	90480-16561	GROMMET	1				
	90480-17004	GROMMET		1	1	1	
21	90387-063G3	COLLAR	1				
	90387-06121	COLLAR		1	1	1	

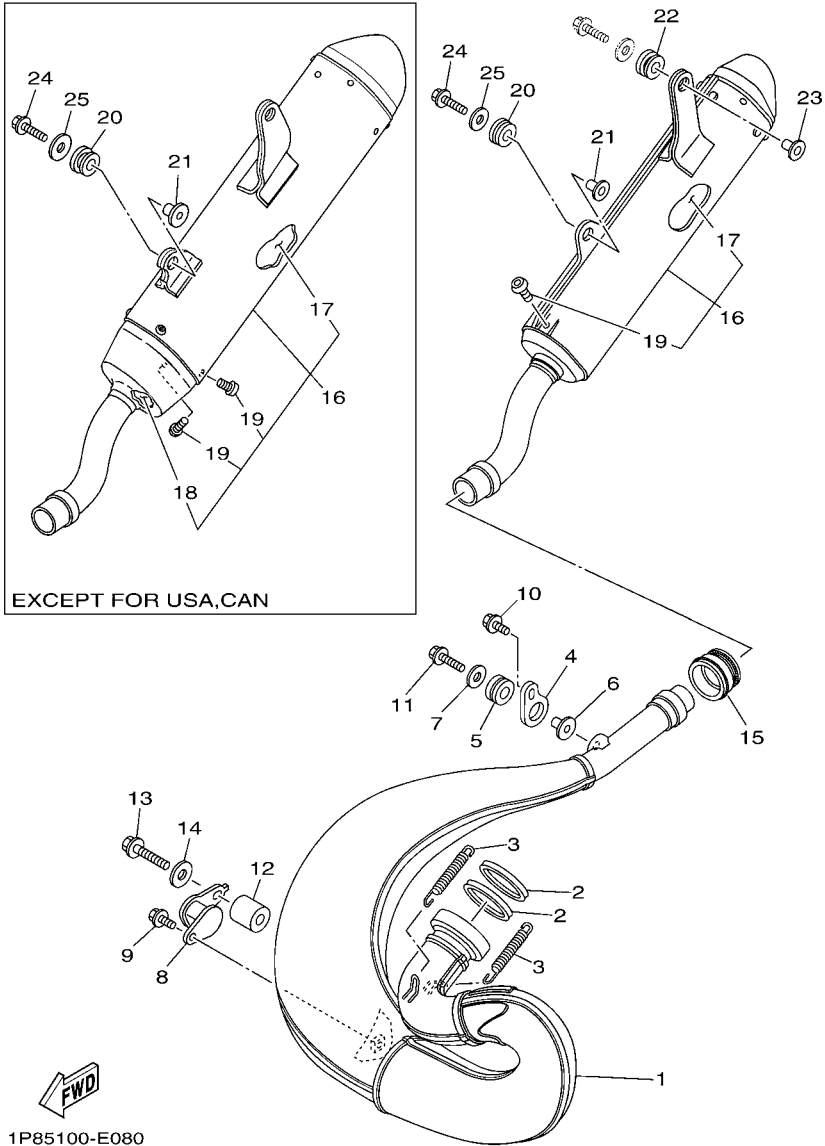

1P85100-E080

FIG. 8 EXHAUST

REF. NO.	PART NO.	DESCRIPTION	1P85	1P86	1P87	1P88	REMARKS
22	90480-16404	GROMMET	1	1	1	1	
23	90387-06039	COLLAR	1	1	1	1	
24	95022-06030	BOLT, FLANGE	1	1	1	1	
25	90201-06033	WASHER, PLATE	1				
	90201-060A3	WASHER, PLATE		1	1	1	
<hr style="border-top: 1px dashed black;"/>							
<hr style="border-top: 1px dashed black;"/>							
<hr style="border-top: 1px dashed black;"/>							
<hr style="border-top: 1px dashed black;"/>							
<hr style="border-top: 1px dashed black;"/>							
<hr style="border-top: 1px dashed black;"/>							
<hr style="border-top: 1px dashed black;"/>							

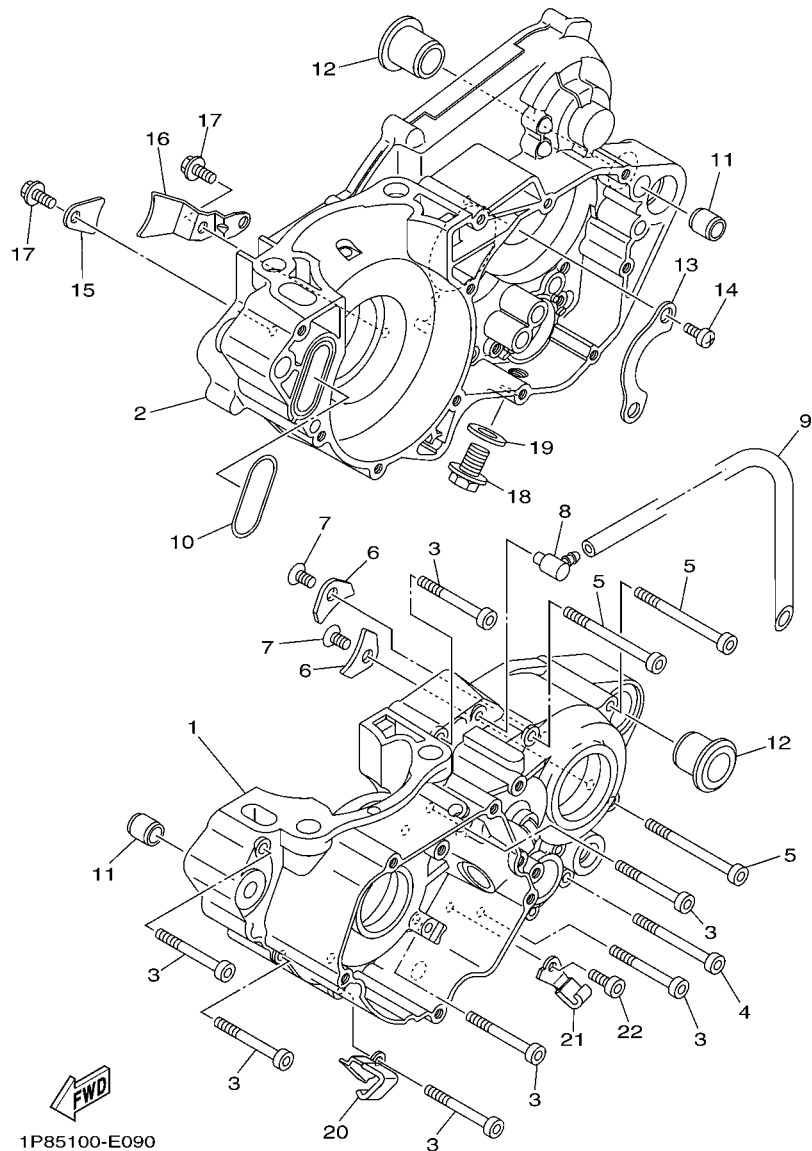

1P85100-E090

FIG. 9 CRANKCASE

REF. NO.	PART NO.	DESCRIPTION	1P85	1P86	1P87	1P88	REMARKS
1	5NX-15111-01	CRANKCASE 1	1				
	1P8-15111-00	CRANKCASE 1		1	1	1	
2	5NX-15121-00	CRANKCASE 2	1	1	1	1	
3	91317-06050	BOLT	7	7	7	7	
4	91317-06060	BOLT	1	1	1	1	
5	91317-06070	BOLT	3	3	3	3	
6	4JT-15381-01	PLATE, BEARING COVER	2	2	2	2	
7	90149-06326	SCREW	2	2	2	2	
8	353-13115-01	CONNECTOR, SUCTION PIPE	1	1	1	1	
9	90445-08376	HOSE (L330)	1	1	1	1	
10	5CU-15454-00	GASKET, AIR CLEANER COVER 1	1	1	1	1	
11	93612-16254	PIN, DOWEL	2	2	2	2	
12	90387-18007	COLLAR	2	2	2	2	
13	4L0-17471-00	PLATE, COVER	1	1	1	1	
14	90157-06077	SCREW, PAN HEAD	2	2	2	2	
15	4V4-15118-00	HOLDER	1	1	1	1	
16	5CU-15118-10	HOLDER	1	1	1	1	
17	90105-06085	BOLT, FLANGE	2	2	2	2	
18	90340-12006	PLUG, STRAIGHT SCREW	1	1	1	1	
19	90430-12227	GASKET	1	1	1	1	
20	90462-08040	CLAMP		1	1	1	
21	90462-08041	CLAMP		1	1	1	
22	91317-06012	BOLT		1	1	1	

FIG. 10 CRANKCASE COVER 1

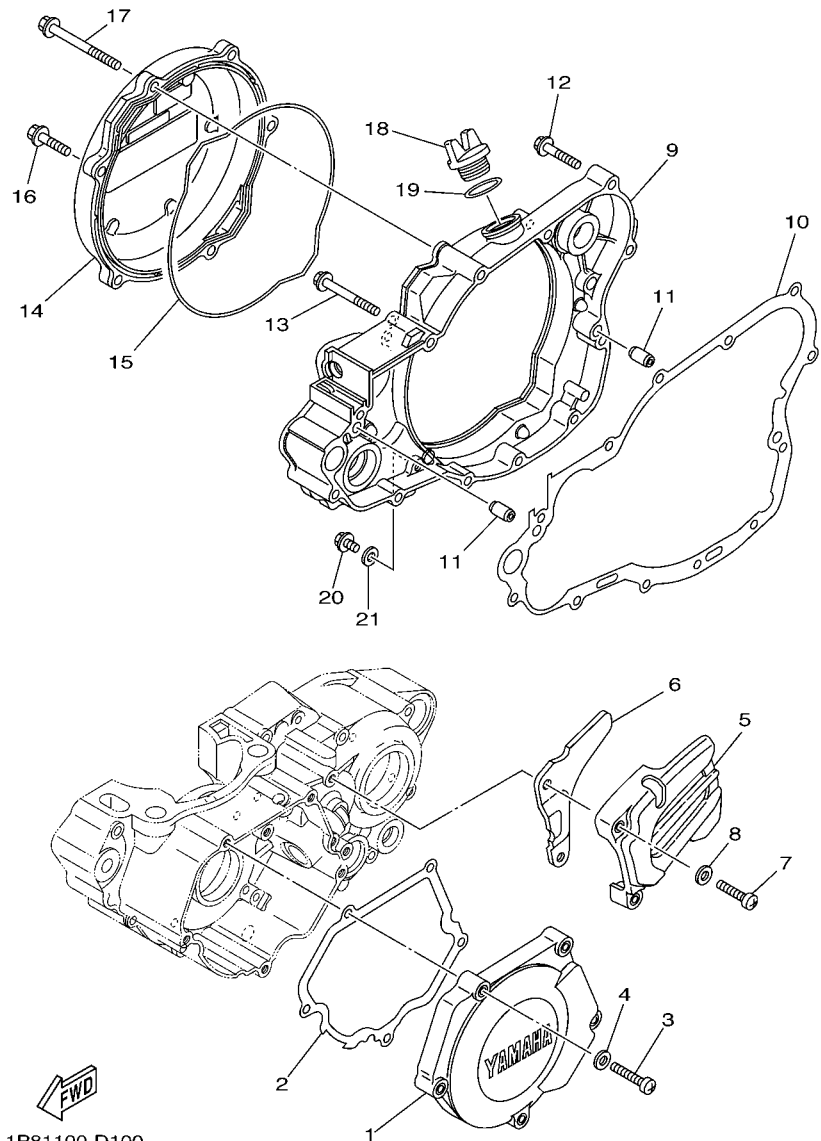

REF. NO.	PART NO.	DESCRIPTION	1P85	1P86	1P87	1P88	REMARKS
1	5CU-15411-10	COVER, CRANKCASE 1	1	1	1	1	
2	5CU-15451-00	GASKET, CRANKCASE COVER 1	1	1	1	1	
3	98507-06030	SCREW, PAN HEAD	5	5	5	5	
4	92907-06600	WASHER, PLATE	5	5	5	5	
5	1P8-15421-10	COVER, CRANKCASE 2	1	1	1	1	
6	5HC-17466-00	GUIDE, CHAIN	1	1	1	1	
7	98507-06030	SCREW, PAN HEAD	2	2	2	2	
8	92907-06600	WASHER, PLATE	2	2	2	2	
9	5NX-15431-00	COVER, CRANKCASE 3	1	1	1	1	
10	5CU-15462-00	GASKET, CRANKCASE COVER 3	1	1	1	1	
11	99530-08016	PIN, DOWEL	2	2	2	2	
12	95027-06030	BOLT, FLANGE	8	8	8	8	
13	95027-06050	BOLT, FLANGE	1	1	1	1	
14	5MW-15415-10	COVER, GENERATOR	1	1	1	1	
15	5CU-15463-00	GASKET, CARBURETOR COVER 2	1	1	1	1	
16	95027-06025	BOLT, FLANGE	5	5	5	5	
17	95027-06065	BOLT, FLANGE	1	1	1	1	
18	3Y1-15363-00	PLUG, OIL	1	1	1	1	
19	93210-19123	O-RING	1	1	1	1	
20	95027-06010	BOLT, FLANGE	1	1	1	1	
21	90430-06014	GASKET	1	1	1	1	

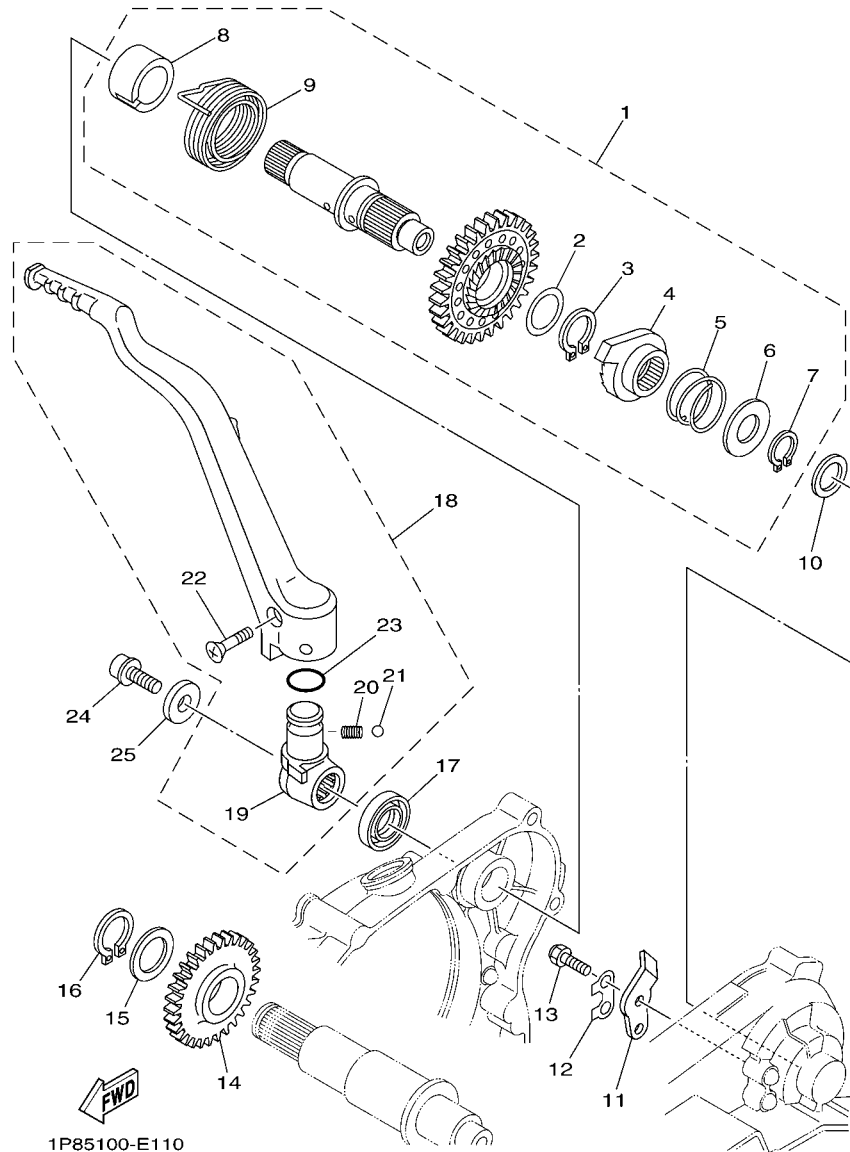
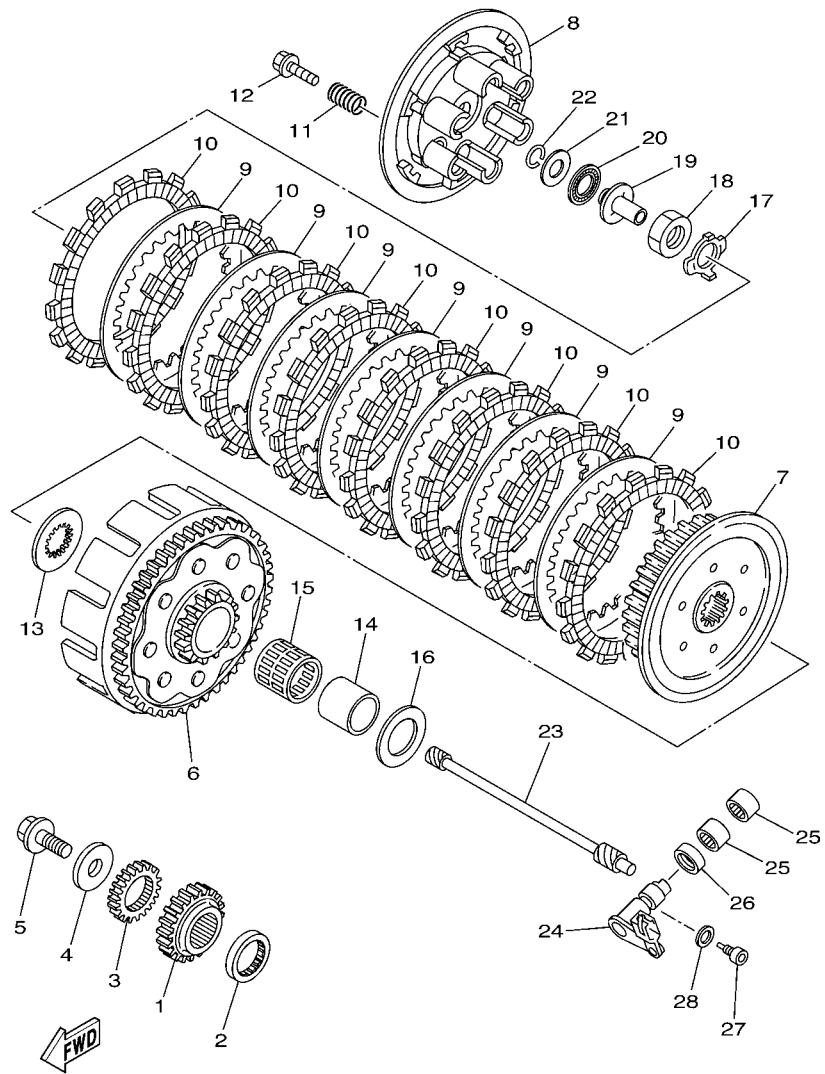

FIG. 11 STARTER

REF. NO.	PART NO.	DESCRIPTION	1P85	1P86	1P87	1P88	REMARKS
1	5NX-15601-10	KICK SHAFT ASSY	1	1	1	1	
2	90201-20685	.WASHER, PLATE (T=0.5)	1	1	1	1	
3	93410-20038	.CIRCLIP	1	1	1	1	
4	4GY-15671-00	.WHEEL, RATCHET	1	1	1	1	
5	90501-16016	.SPRING, COMPRESSION	1	1	1	1	
6	90201-167P7	.WASHER, PLATE	1	1	1	1	
7	99009-16400	.CIRCLIP	1	1	1	1	
8	5NL-15664-00	.GUIDE, SPRING	1	1	1	1	
9	90508-30743	.SPRING, TORSION	1	1	1	1	
10	90201-162H4	WASHER, PLATE	1	1	1	1	
11	214-15674-00	GUIDE, RATCHET WHEEL	1	1	1	1	
12	214-15686-00	WASHER, LOCK	1	1	1	1	
13	97027-06016	BOLT	2	2	2	2	
14	5CU-15651-00	GEAR, KICK IDLE	1	1	1	1	
15	90201-20276	WASHER, PLATE (T=1.0)	1	1	1	1	
16	99009-20400	CIRCLIP	1	1	1	1	
17	93102-18278	OIL SEAL	1	1	1	1	
18	5NX-15620-11	KICK CRANK ASSY	1	1	1	1	
19	5NX-15621-10	.BOSS, KICK CRANK	1	1	1	1	
20	90501-147A5	.SPRING, COMPRESSION	1	1	1	1	
21	93507-32009	.BALL	1	1	1	1	
22	90152-06010	.SCREW, COUNTERSUNK	1	1	1	1	
23	93210-17570	.O-RING	1	1	1	1	
24	90110-08052	BOLT, HEXAGON SOCKET HEAD	1	1	1	1	
25	90201-08048	WASHER, PLATE	1	1	1	1	



5NX1100-A120

FIG. 12 CLUTCH

REF. NO.	PART NO.	DESCRIPTION	1P85	1P86	1P87	1P88	REMARKS
1	5DJ-16111-00	GEAR, PRIMARY DRIVE	1	1	1	1	
2	5MW-16113-00	WASHER, THRUST 1	1	1	1	1	
3	5CU-11956-00	GEAR, GOVERNOR DRIVE	1	1	1	1	
4	90201-105P3	WASHER, PLATE	1	1	1	1	
5	90105-10445	BOLT, FLANGE	1	1	1	1	
6	5DJ-16150-00	PRIMARY DRIVEN GEAR COMP.	1	1	1	1	
7	5NX-16371-00	BOSS, CLUTCH	1	1	1	1	
8	5JG-16351-00	PLATE, PRESSURE 1	1	1	1	1	
9	4X7-16325-00	PLATE, CLUTCH 2	7	7	7	7	
10	3XK-16321-00	PLATE, FRICTION	8	8	8	8	
11	90501-237L0	SPRING, COMPRESSION	6	6	6	6	
12	90159-06010	SCREW, WITH WASHER	6	6	6	6	
13	5CU-16154-00	PLATE, THRUST 1	1	1	1	1	
14	2VM-16181-00	SPACER 1	1	1	1	1	
15	93310-230T7	BEARING	1	1	1	1	
16	2K7-16154-00	PLATE, THRUST 1	1	1	1	1	
17	90215-20231	WASHER, LOCK	1	1	1	1	
18	90170-20255	NUT	1	1	1	1	
19	4XL-16356-00	ROD, PUSH 1	1	1	1	1	
20	93340-21505	BEARING	1	1	1	1	
21	90201-125L6	WASHER, PLATE	1	1	1	1	
22	93440-10085	CIRCLIP	1	1	1	1	
23	1P8-16357-00	ROD, PUSH 2	1	1	1	1	
24	5CU-16380-10	PUSH LEVER ASSY	1	1	1	1	
25	93315-11206	BEARING	2	2	2	2	
26	93102-12224	OIL SEAL	1	1	1	1	
27	90109-056G0	BOLT	1	1	1	1	

FIG. 12 CLUTCH

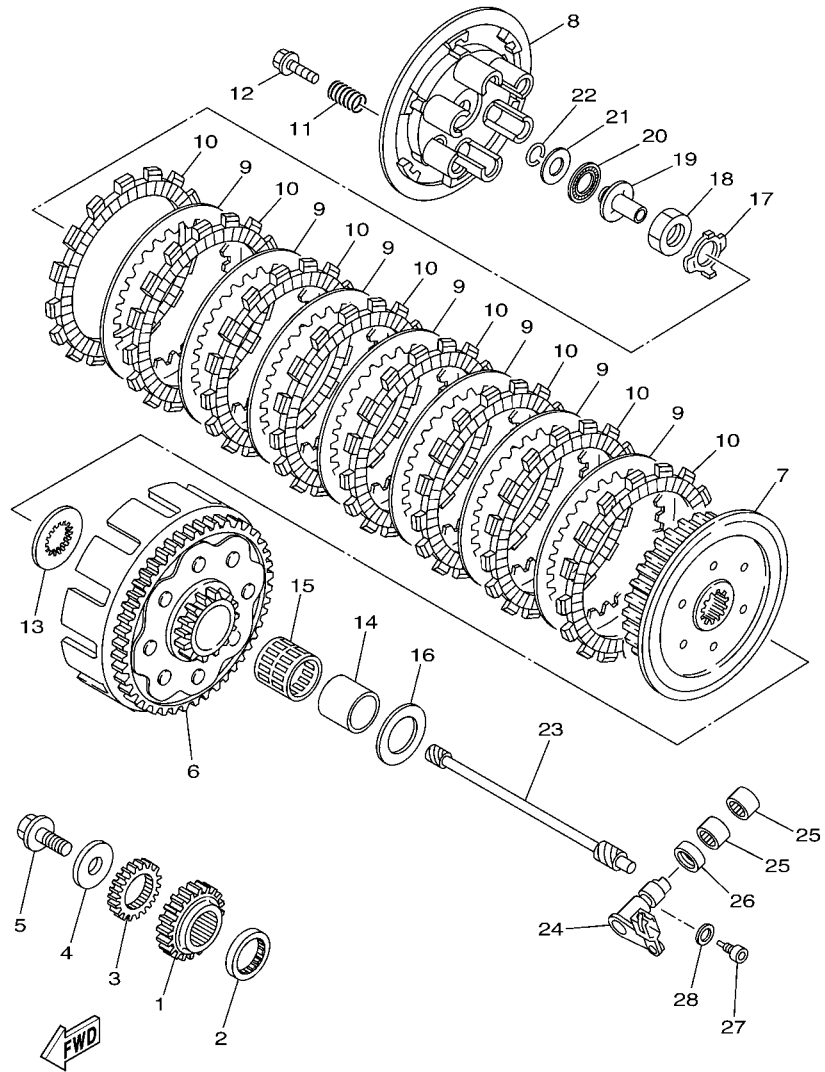

5NX1100-A120

REF. NO.	PART NO.	DESCRIPTION	1P85	1P86	1P87	1P88	REMARKS
28	90430-05242	GASKET	1	1	1	1	

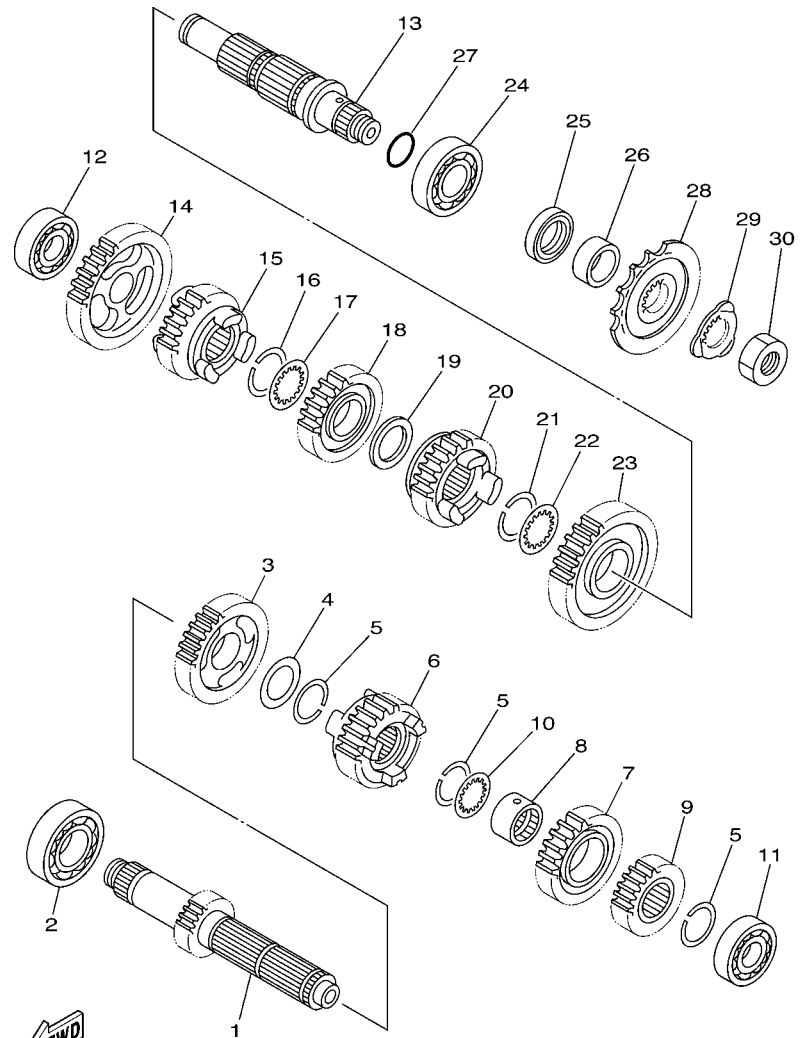

5CU1100-9130

FIG. 13 TRANSMISSION

REF. NO.	PART NO.	DESCRIPTION	1P85	1P86	1P87	1P88	REMARKS
1	5BE-17411-00	AXLE, MAIN (14T)	1	1	1	1	
2	93306-20540	BEARING	1	1	1	1	
3	5BE-17151-00	GEAR, 5TH PINION (21T)	1	1	1	1	
4	90201-253K0	WASHER, PLATE (T=1.0)	1	1	1	1	
5	93440-25084	CIRCLIP	3	3	3	3	
6	5CU-17131-01	GEAR, 3RD PINION (18T)	1	1	1	1	
7	5BE-17141-30	GEAR, 4TH PINION (22T)	1	1	1	1	
8	90387-2113G	COLLAR	1	1	1	1	
9	5JG-17121-10	GEAR, 2ND PINION (15T)	1	1	1	1	
10	90209-21332	WASHER	1	1	1	1	
11	93306-00442	BEARING	1	1	1	1	
12	93306-00426	BEARING	1	1	1	1	
13	5BE-17402-00	DRIVE AXLE ASSY	1	1	1	1	
14	5BE-17211-00	GEAR, 1ST WHEEL (27T)	1	1	1	1	
15	5BE-17251-10	GEAR, 5TH WHEEL (20T)	1	1	1	1	
16	93440-25084	CIRCLIP	1	1	1	1	
17	90209-21332	WASHER	1	1	1	1	
18	5BE-17231-00	GEAR, 3RD WHEEL (23T)	1	1	1	1	
19	90201-253K0	WASHER, PLATE (T=1.0)	1	1	1	1	
20	5JG-17241-00	GEAR, 4TH WHEEL (24T)	1	1	1	1	
21	93440-28062	CIRCLIP	1	1	1	1	
22	90209-26348	WASHER	1	1	1	1	
23	5JG-17221-10	GEAR, 2ND WHEEL (23T)	1	1	1	1	
24	93306-20574	BEARING	1	1	1	1	
25	93102-32337	OIL SEAL	1	1	1	1	
26	90387-2515B	COLLAR	1	1	1	1	
27	93210-22298	O-RING	1	1	1	1	

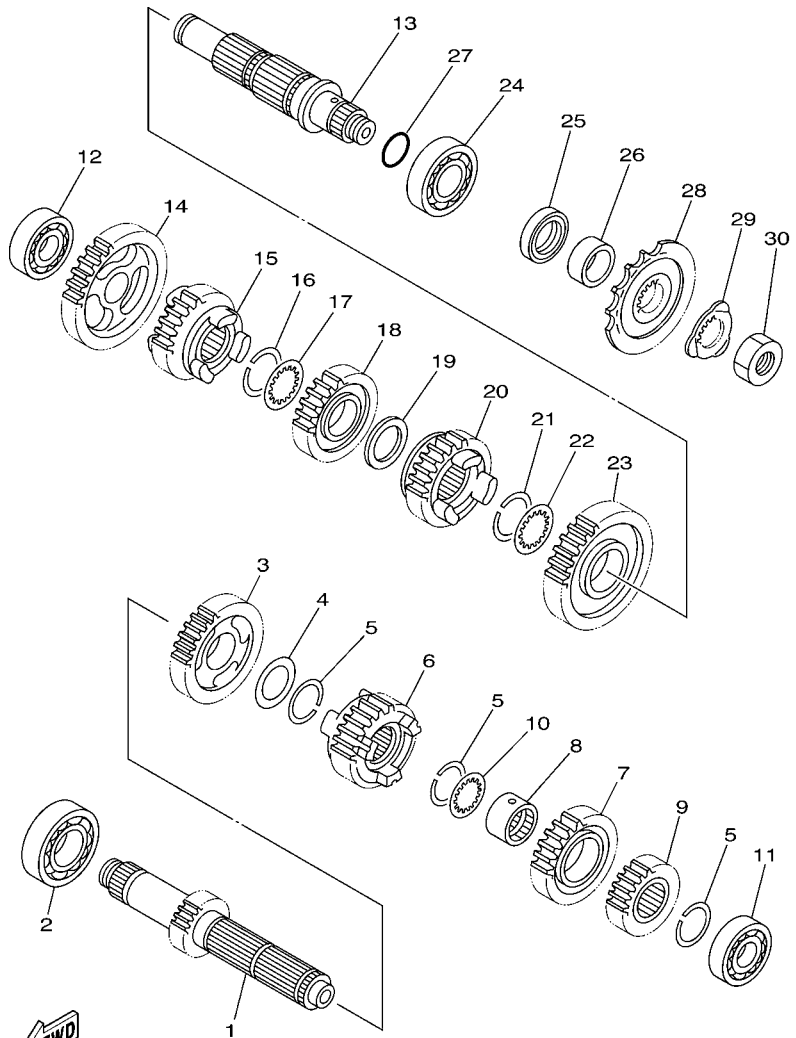

5CU1100-9130

FIG. 13 TRANSMISSION

REF. NO.	PART NO.	DESCRIPTION	1P85	1P86	1P87	1P88	REMARKS
28	9383E-14215	SPROCKET, DRIVE (14T)	1	1	1	1	STD
	9383E-13216	SPROCKET, DRIVE (13T)	1	1	1	1	AP
29	90215-21256	WASHER, LOCK	1	1	1	1	
30	90179-20255	NUT	1	1	1	1	

FIG. 14 SHIFT CAM & FORK

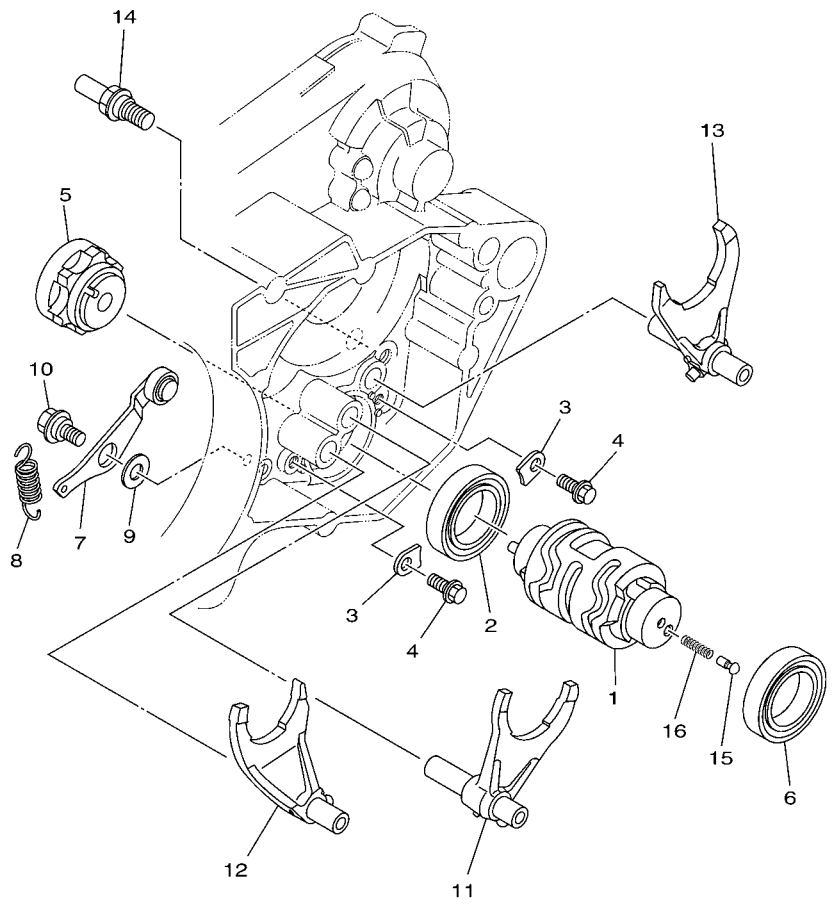

FWD
1P85100-E140

REF. NO.	PART NO.	DESCRIPTION	1P85	1P86	1P87	1P88	REMARKS
1	1P8-18541-00	CAM, SHIFT	1	1	1	1	
2	93306-90506	BEARING	1	1	1	1	
3	5DH-18562-00	PLATE, STOPPER 2	2	2	2	2	
4	90105-06553	BOLT, FLANGE	2	2	2	2	
5	4EW-18185-00	SEGMENT	1	1	1	1	
6	93306-90501	BEARING	1	1	1	1	
7	5CU-18140-01	STOPPER LEVER ASSY	1	1	1	1	
8	90507-14064	SPRING, TENSION	1	1	1	1	
9	90201-06013	WASHER, PLATE	1	1	1	1	
10	90109-066G1	BOLT	1	1	1	1	
11	5BE-18501-20	FORK, SHIFT 1	1	1	1	1	
12	5BE-18502-20	FORK, SHIFT 2	1	1	1	1	
13	5CU-18503-20	FORK, SHIFT 3	1	1	1	1	
14	4BR-18127-10	STOPPER, SCREW	1	1	1	1	
15	4UN-18542-00	POINT, NEUTRAL		1	1	1	
16	90501-06022	SPRING, COMPRESSION		1	1	1	

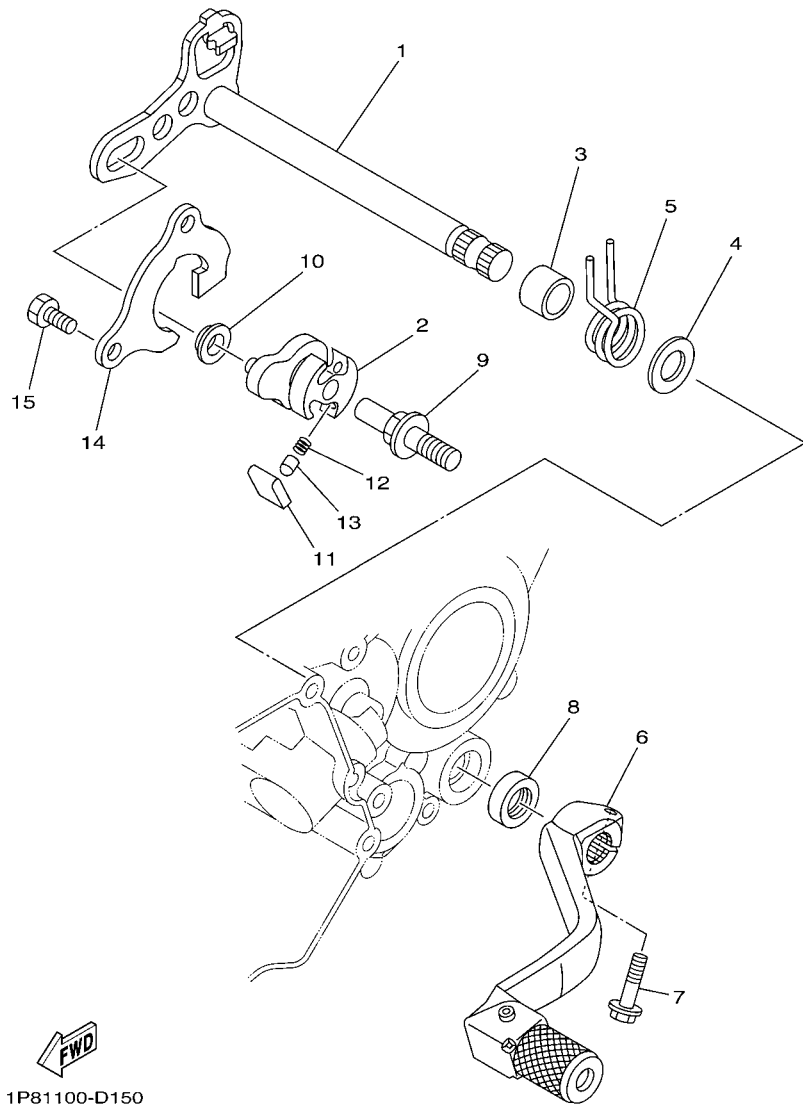

1P81100-D150

FIG. 15 SHIFT SHAFT

REF. NO.	PART NO.	DESCRIPTION	1P85	1P86	1P87	1P88	REMARKS
1	5CU-18101-10	SHIFT SHAFT ASSY	1	1	1	1	
2	5MW-18122-01	LEVER, SHIFT 2	1	1	1	1	
3	90387-124F4	COLLAR	1	1	1	1	
4	90201-12575	WASHER, PLATE	1	1	1	1	
5	90508-291A8	SPRING, TORSION	1	1	1	1	
6	1C3-18110-00	SHIFT PEDAL ASSY	1	1	1	1	
7	95027-06020	BOLT, FLANGE	1	1	1	1	
8	93102-12224	OIL SEAL	1	1	1	1	
9	3XJ-18173-10	PIN, SHIFT	1	1	1	1	
10	3XJ-18178-00	ROLLER, SHIFT LEVER	1	1	1	1	
11	3XJ-18182-00	PAWL, SHIFTER	2	2	2	2	
12	90501-052G5	SPRING, COMPRESSION	2	2	2	2	
13	3XJ-18184-00	PIN, PAWL	2	2	2	2	
14	5CU-18172-00	GUIDE, SHIFT	1	1	1	1	
15	90101-06041	BOLT	2	2	2	2	

FIG. 16 FRAME

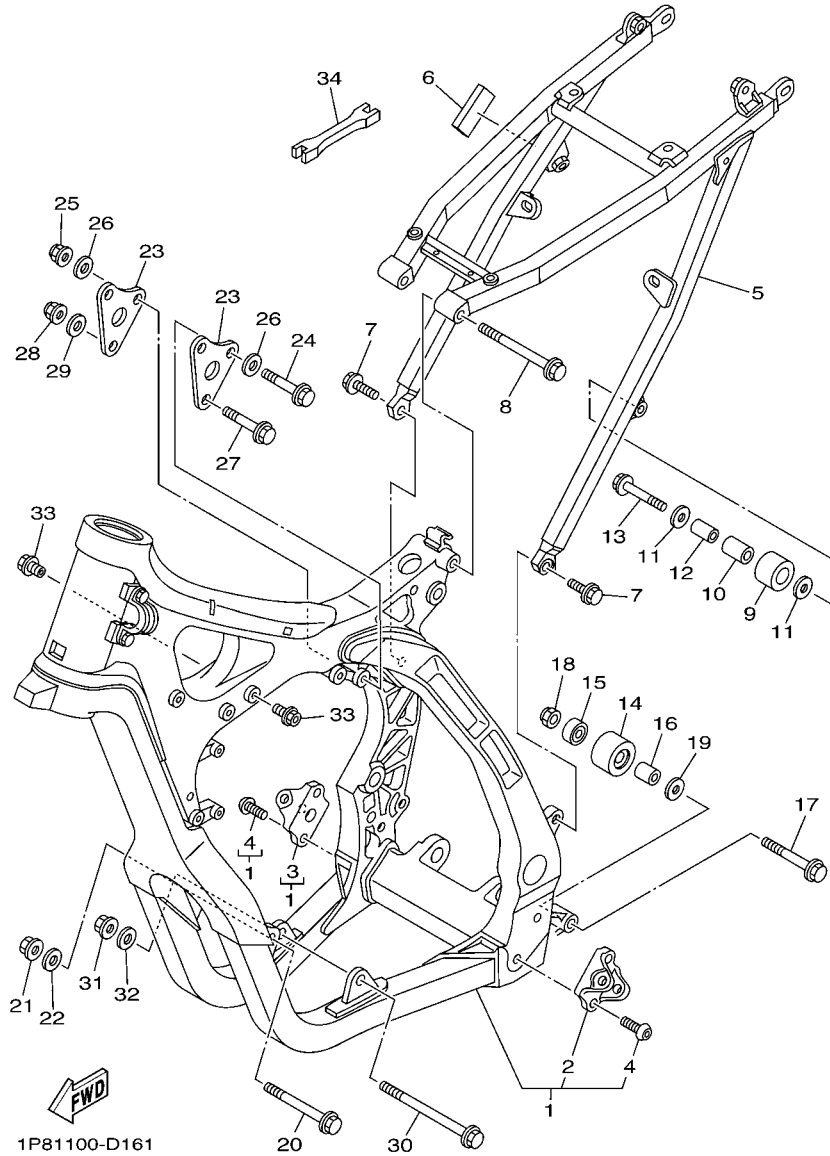

REF. NO.	PART NO.	DESCRIPTION	1P85	1P86	1P87	1P88	REMARKS
1	1P8-21101-50	FRONT FRAME COMP.	1	1	1	1	
2	1C3-21447-10	.BRACKET, FOOTREST	1	1	1	1	
3	1C3-21448-10	.BRACKET, FOOTREST	1	1	1	1	
4	90149-10031	.SCREW	4	4	4	4	
5	1C3-21190-50	REAR FRAME COMP.	1	1	1	1	
6	5GJ-21717-00	DAMPER	1	1	1	1	
7	90105-08085	BOLT, FLANGE	2	2	2	2	
8	90105-08120	BOLT, FLANGE	1	1	1	1	
9	30X-22178-00	TENSIONER	1	1	1	1	
10	4V4-22184-00	BUSH	1	1	1	1	
11	90201-08045	WASHER, PLATE	2	2	2	2	
12	90387-08041	COLLAR	1	1	1	1	
13	95022-08040	BOLT, FLANGE	1	1	1	1	
14	3JD-22178-20	TENSIONER	1	1	1	1	
15	93300-60839	BEARING	1	1	1	1	
16	90387-086N4	COLLAR	1	1	1	1	
17	95024-08055	BOLT,FLG,(SMALL HEAD)	1	1	1	1	
18	90185-08009	NUT, SELF-LOCKING	1	1	1	1	
19	90201-08043	WASHER, PLATE	1	1	1	1	
20	90105-10733	BOLT, FLANGE	1	1	1	1	
21	90179-10658	NUT	1	1	1	1	
22	92907-10200	WASHER, PLAIN	1	1	1	1	
23	5NX-21425-00	BRACKET, REAR UPPER 1	2	2	2	2	
24	90105-08059	BOLT, FLANGE	2	2	2	2	
25	90179-08674	NUT	2	2	2	2	
26	90201-08730	WASHER, PLATE	4	4	4	4	
27	90105-10074	BOLT, FLANGE	1	1	1	1	

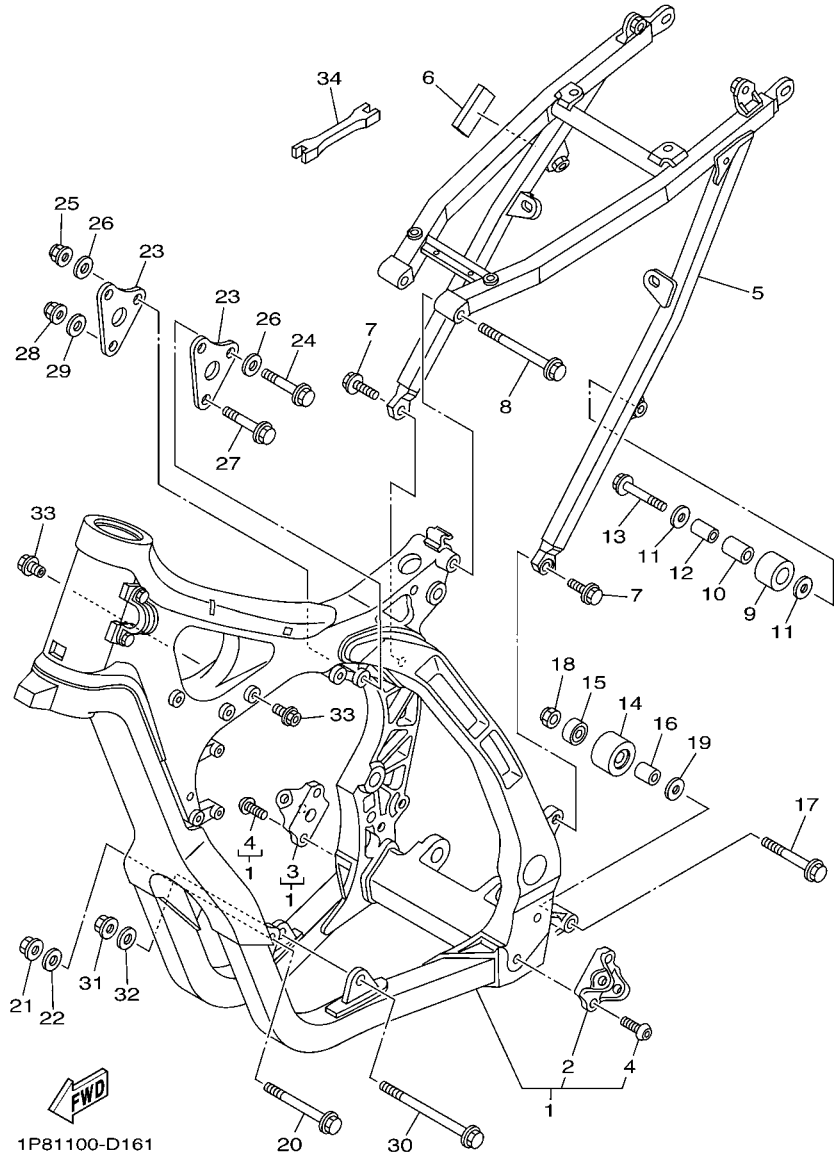

FIG. 16 FRAME

REF. NO.	PART NO.	DESCRIPTION	1P85	1P86	1P87	1P88	REMARKS
28	90179-10658	NUT	1	1	1	1	
29	92907-10200	WASHER, PLAIN	1	1	1	1	
30	90105-10079	BOLT, FLANGE	1	1	1	1	
31	90179-10658	NUT	1	1	1	1	
32	92907-10200	WASHER, PLAIN	1	1	1	1	
33	1C3-21244-10	NUT	2	2	2	2	
34	5ET-28166-10	WRENCH, HEXAGON	1	1	1	1	

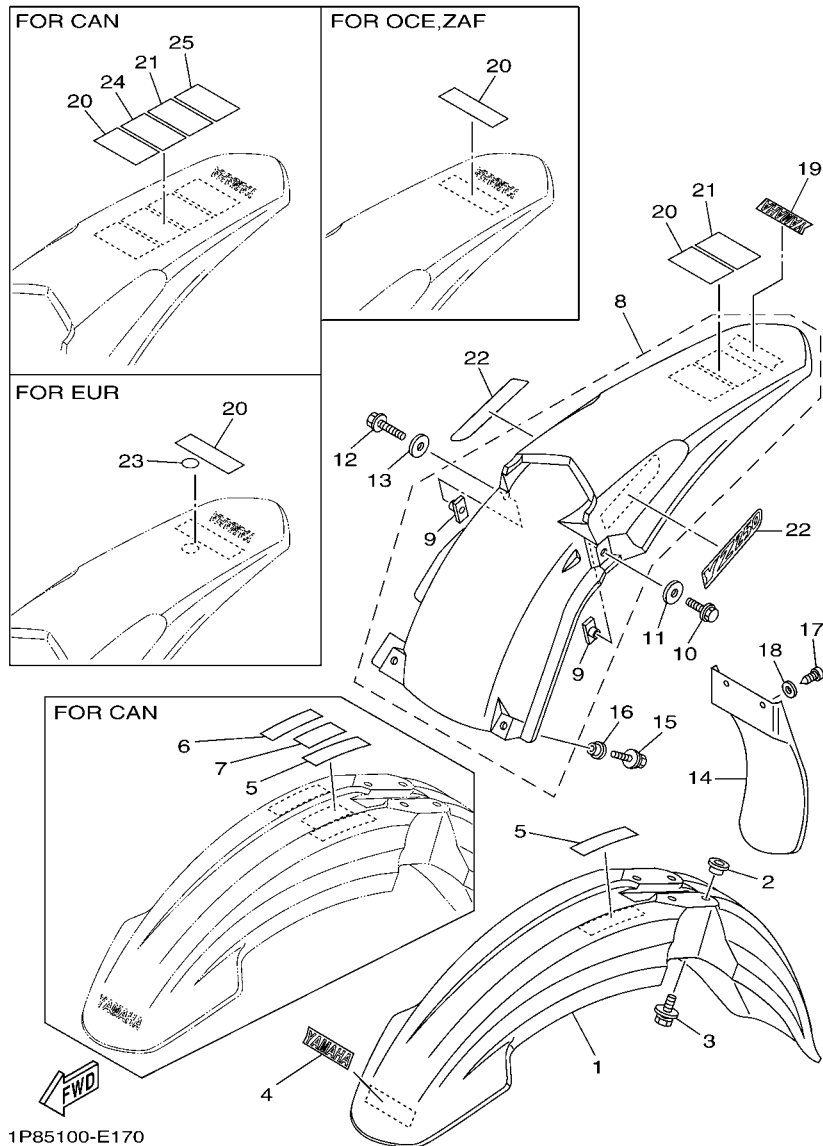

FIG. 17 FENDER

REF. NO.	PART NO.	DESCRIPTION	1P85	1P86	1P87	1P88	REMARKS
1	1C3-21511-50	FENDER, FRONT	1	1	1	1	
2	90387-06090	COLLAR	4	4	4	4	
3	90119-06096	BOLT, WITH WASHER	4	4	4	4	
4	4ES-2153E-01	EMBLEM, YAMAHA	1	1	1	1	
5	3XJ-2415E-A0	LABEL, CAUTION	1				
6	3XJ-2415E-B0	LABEL, CAUTION	1				FOR CAN
7	4SR-2416E-00	LABEL, CAUTION CANADA	1				FOR CAN
8	5XE-21610-10	REAR FENDER COMP.	1	1	1	1	
9	5XE-21635-10	.NUT, REAR FENDER	2	2	2	2	
10	90105-06063	BOLT, FLANGE	1	1	1	1	
11	90201-06032	WASHER, PLATE	1	1	1	1	
12	90105-06062	BOLT, FLANGE	1	1	1	1	
13	90201-06033	WASHER, PLATE	1	1	1	1	
14	5UN-21642-10	GUARD, FLAP	1	1	1	1	
15	90119-06225	BOLT, WITH WASHER	2	2	2	2	
16	90387-06009	COLLAR	2	2	2	2	
17	97707-60016	SCREW, TAPPING	2	2	2	2	
18	90201-06557	WASHER, PLATE	2	2	2	2	
19	4ES-2153E-01	EMBLEM, YAMAHA	1	1	1	1	
20	5PA-2118K-00	LABEL, CAUTION	1				
	5PA-21568-00	LABEL, WARNING		1		1	
	5PA-2118K-20	LABEL, CAUTION			1		
21	3XJ-2151H-A1	LABEL 5	1				
	4LB-2151H-02	LABEL 5			1		
22	1P8-2163G-00	EMBLEM 1	2	2	2	2	
23	3ME-2415E-01	LABEL, CAUTION		1			

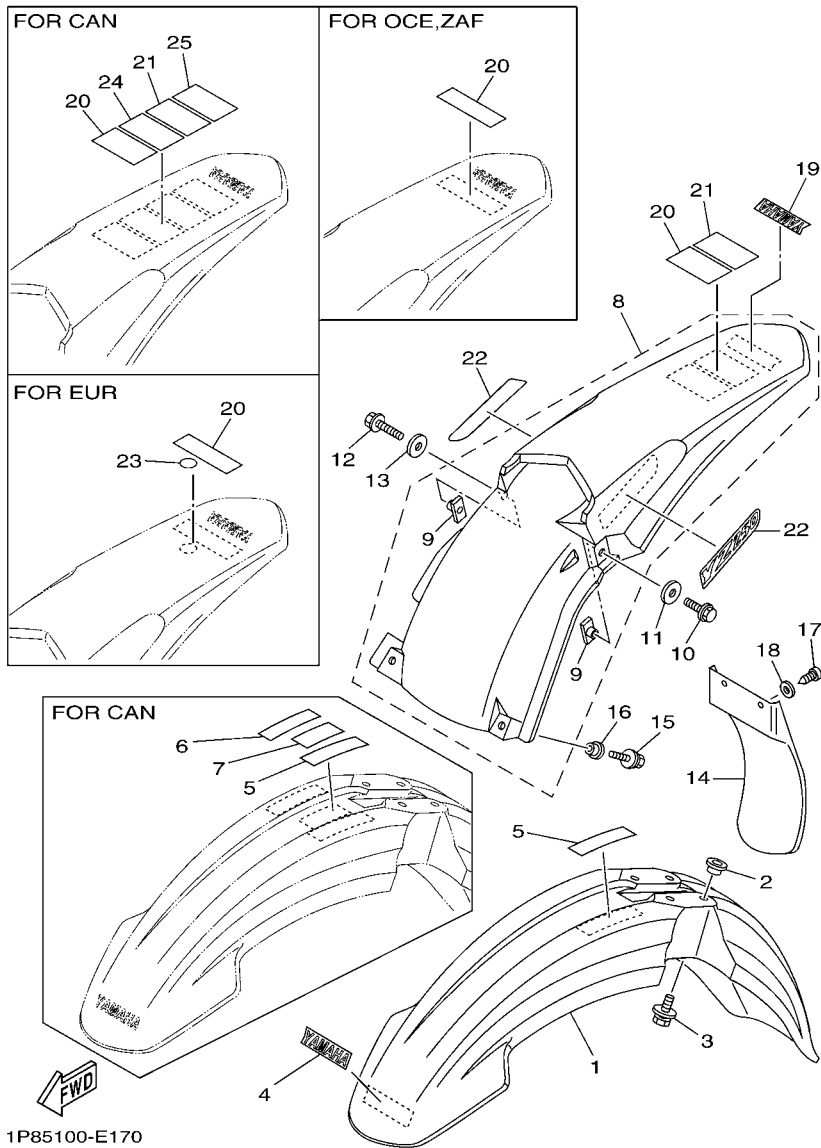
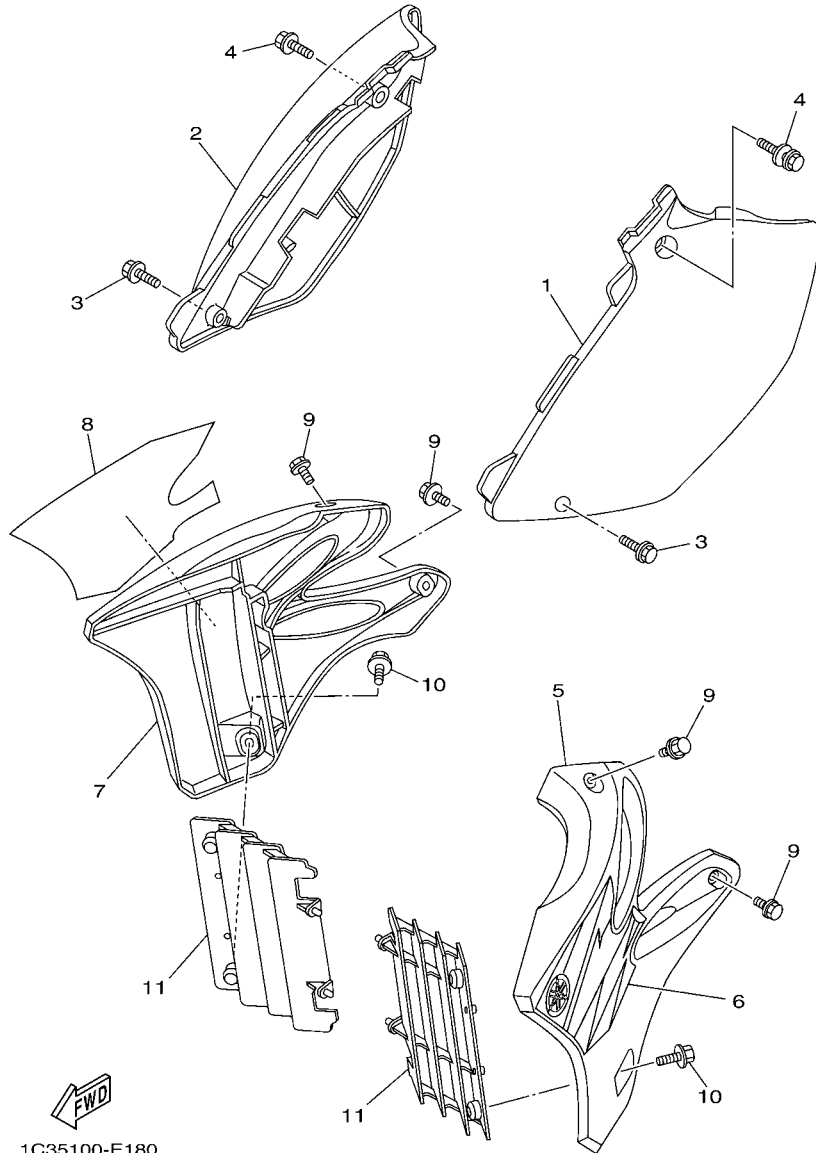

FIG. 17 FENDER

REF. NO.	PART NO.	DESCRIPTION	1P85	1P86	1P87	1P88	REMARKS
24	5PA-2118K-10	LABEL, CAUTION	1				FOR CAN
25	3XJ-2151H-B1	LABEL 5	1				FOR CAN

FIG. 18 SIDE COVER



REF. NO.	PART NO.	DESCRIPTION	1P85	1P86	1P87	1P88	REMARKS
1	5NY-21711-00	COVER, SIDE 1	1	1	1	1	
2	5NY-21721-00	COVER, SIDE 2	1				
	1C3-21721-50	COVER, SIDE 2		1	1	1	
3	95824-06016	BOLT, FLANGE	2	2	2	2	
4	90119-08086	BOLT, WITH WASHER	2	2	2	2	
5	5XE-21730-00	SIDE COVER ASSY 3	1	1	1	1	
6	1C3-2173E-10	GRAPHIC 1	1	1	1	1	
7	5XE-21740-00	SIDE COVER ASSY 4	1	1	1	1	
8	1C3-2173F-10	GRAPHIC 2	1	1	1	1	
9	90105-06064	BOLT, FLANGE	4	4	4	4	
10	90159-06021	SCREW, WITH WASHER	2	2	2	2	
11	5NL-2172A-20	PANEL 1	2	2	2	2	

FIG. 19 REAR ARM

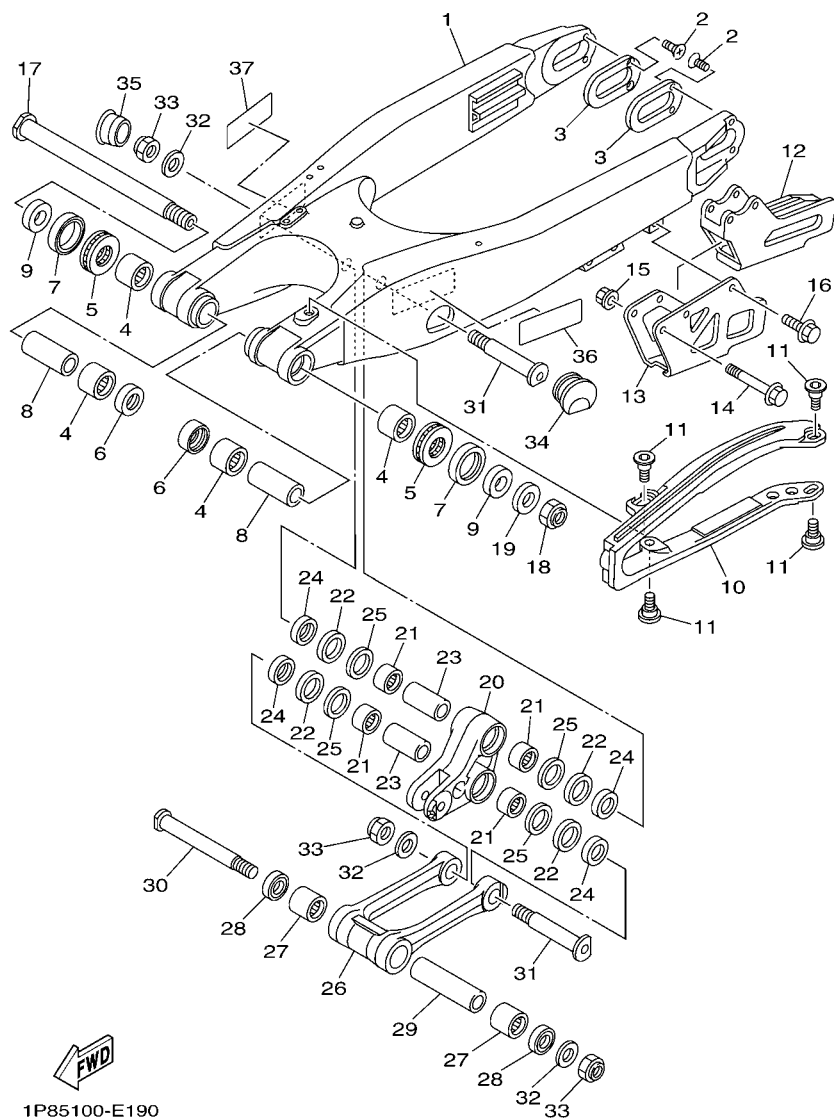

1P85100-E190

REF. NO.	PART NO.	DESCRIPTION	1P85	1P86	1P87	1P88	REMARKS
1	1C3-22110-50	REAR ARM COMP.	1	1	1	1	
2	90151-04001	SCREW, COUNTERSUNK	4	4	4	4	
3	1P8-22355-00	PATCH	2	2	2	2	
4	93317-22262	BEARING	4	4	4	4	
5	93342-22217	BEARING	2	2	2	2	
6	93106-22002	OIL SEAL	2	2	2	2	
7	93109-28043	OIL SEAL	2	2	2	2	
8	90387-18004	COLLAR	2	2	2	2	
9	90387-18011	COLLAR	2	2	2	2	
10	1C3-22151-00	SEAL, GUARD	1	1	1	1	
11	1C3-22969-50	SCREW, 1	4	4	4	4	
12	1C3-22199-10	SUPPORT, CHAIN	1	1	1	1	
13	1C3-22128-00	COVER, THRUST 1	1	1	1	1	
14	95024-06050	BOLT, FLANGE	2	2	2	2	
15	90179-06028	NUT	2	2	2	2	
16	95024-06010	BOLT, FLANGE	1	1	1	1	
17	1C3-22141-10	SHAFT, PIVOT	1	1	1	1	
18	90185-16002	NUT, SELF-LOCKING	1	1	1	1	
19	90201-16018	WASHER, PLATE	1	1	1	1	
20	1C3-2217A-00	ARM, RELAY	1	1	1	1	
21	93315-32166	BEARING	4	4	4	4	
22	93109-25001	OIL SEAL	4	4	4	4	
23	90387-16010	COLLAR	2	2	2	2	
24	90209-16011	WASHER	4	4	4	4	
25	90201-21014	WASHER, PLATE	4	4	4	4	
26	1C3-2217F-50	ROD, CONNECTING 1	1	1	1	1	
27	93315-32166	BEARING	2	2	2	2	

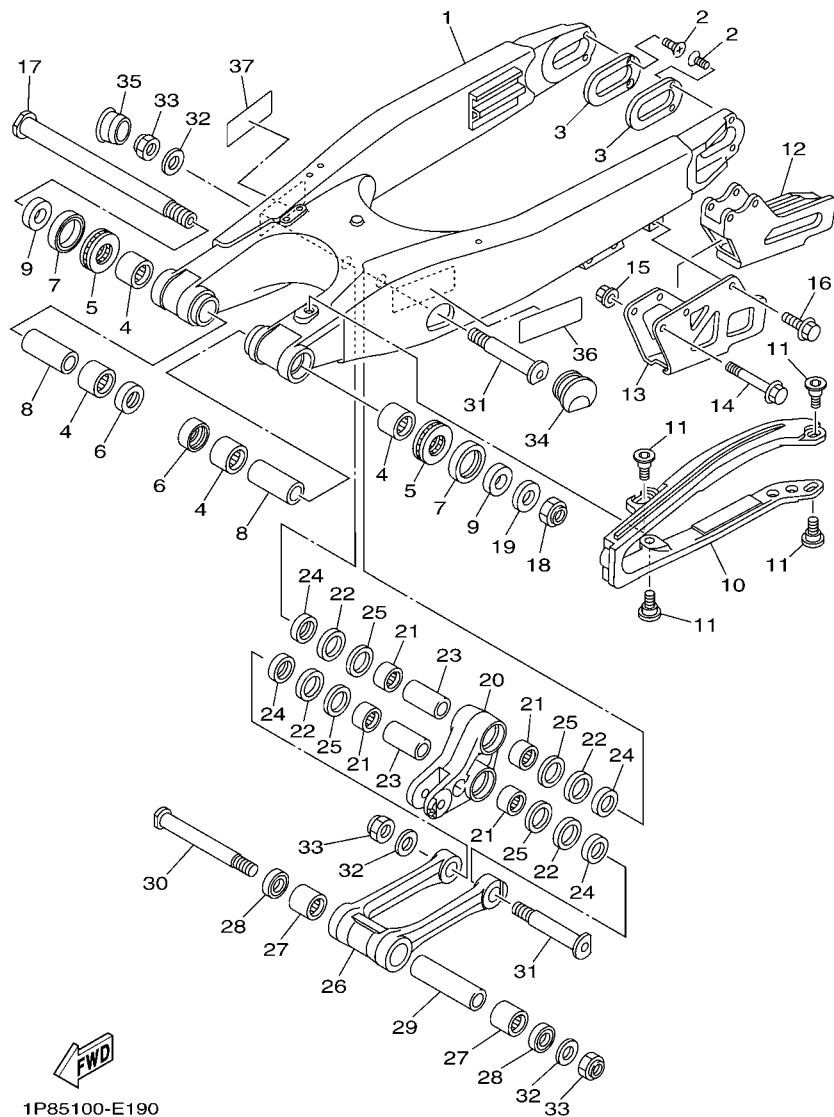

1P85100-E190

FIG. 19 REAR ARM

REF. NO.	PART NO.	DESCRIPTION	1P85	1P86	1P87	1P88	REMARKS
28	93109-21001	OIL SEAL	2	2	2	2	
29	90387-14005	COLLAR	1	1	1	1	
30	1C3-22121-00	SHAFT 1	1	1	1	1	
31	1C3-22122-00	SHAFT 2	2	2	2	2	
32	90201-14740	WASHER, PLATE	3	3	3	3	
33	90185-14007	NUT, SELF-LOCKING	3	3	3	3	
34	1C3-2135F-00	COVER	1	1	1	1	
35	1C3-2139R-00	COVER 2	1	1	1	1	
36	3RV-21668-A0	LABEL, TIRE	1	1		1	
37	3RV-21668-B0	LABEL, TIRE	1				FOR CAN

FIG. 20 REAR SUSPENSION

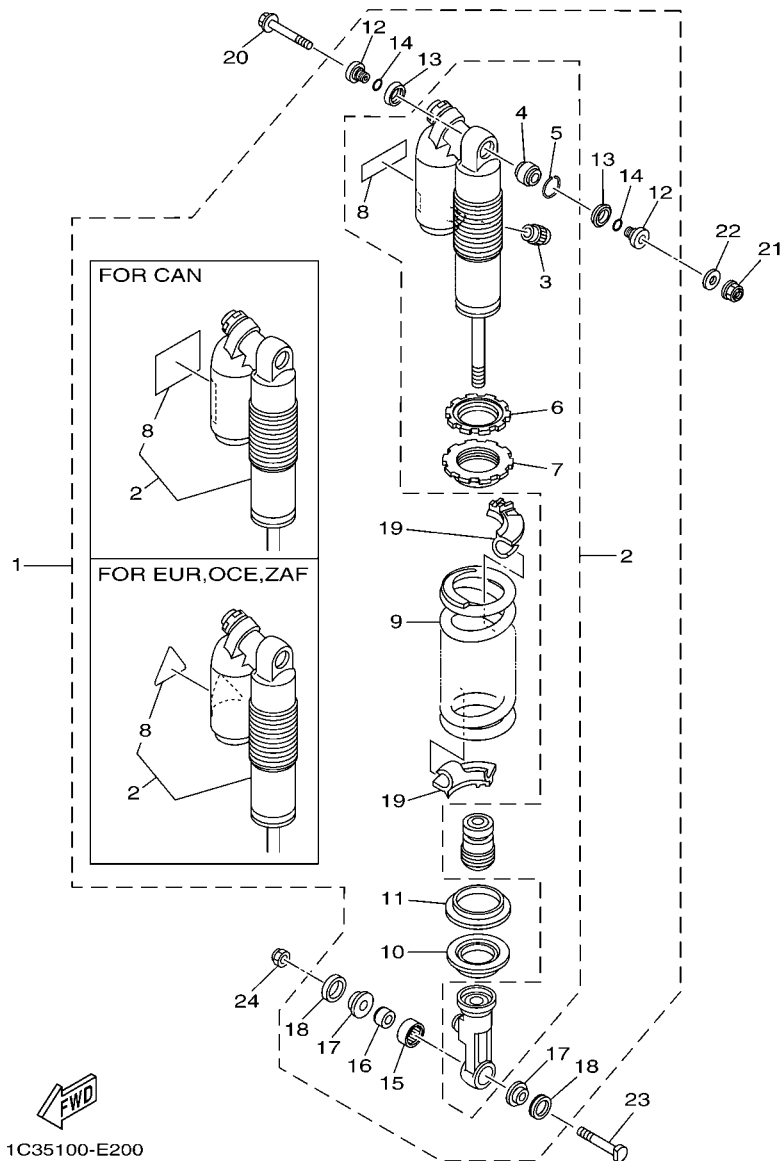

1C35100-E200

REF. NO.	PART NO.	DESCRIPTION	1P85	1P86	1P87	1P88	REMARKS
1	1P8-22200-50	SHOCK ABSORBER ASSY, REAR	1				UR FOR USA
	1P8-22200-90	SHOCK ABSORBER ASSY, REAR	1				UR FOR CAN
	1P8-22200-60	SHOCK ABSORBER ASSY, REAR		1			
	1P8-22200-70	SHOCK ABSORBER ASSY, REAR			1		
	1P8-22200-80	SHOCK ABSORBER ASSY, REAR				1	
2	1P8-22201-50	.DAMPER SUB ASSY	1				UR FOR USA
	1P8-22201-90	.DAMPER SUB ASSY	1				UR FOR CAN
	1P8-22201-60	.DAMPER SUB ASSY		1			
	1P8-22201-70	.DAMPER SUB ASSY			1		
	1P8-22201-80	.DAMPER SUB ASSY				1	
3	509-23184-L0	..CAP, AIR VALVE	1	1	1	1	
4	4JX-22226-00	..BUSH, SHOCK ABSORBER LOWER	1	1	1	1	
5	5DH-23183-00	..CIRCLIP	1	1	1	1	
6	3SP-22234-00	..GUIDE, SPRING 3	1	1	1	1	
7	3SP-22213-00	..SEAT, SPRING UPPER	1	1	1	1	
8	4AA-22259-80	..LABEL, WARNING	1				UR FOR USA
	4AA-22259-60	..LABEL, WARNING	1				UR FOR CAN
	4AA-22259-40	..LABEL, WARNING		1		1	
	4AA-22259-50	..LABEL, WARNING			1		
9	1C3-22212-20	.SPRING (K=48N/MM)	1	1	1	1	
10	1C3-22214-50	.GUIDE, SPRING 1	1	1	1	1	
11	5MV-22224-00	.GUIDE, SPRING 2	1	1	1	1	
12	1C3-22253-50	.COLLAR, DISTANCE	2	2	2	2	
13	3JE-22475-00	.SEAL, DUST	2	2	2	2	
14	4EW-22474-00	.SEAL, RING	2	2	2	2	
15	5UN-22176-00	.BEARING	1	1	1	1	
16	5MV-22184-00	.BUSH	1	1	1	1	

FIG. 20 REAR SUSPENSION

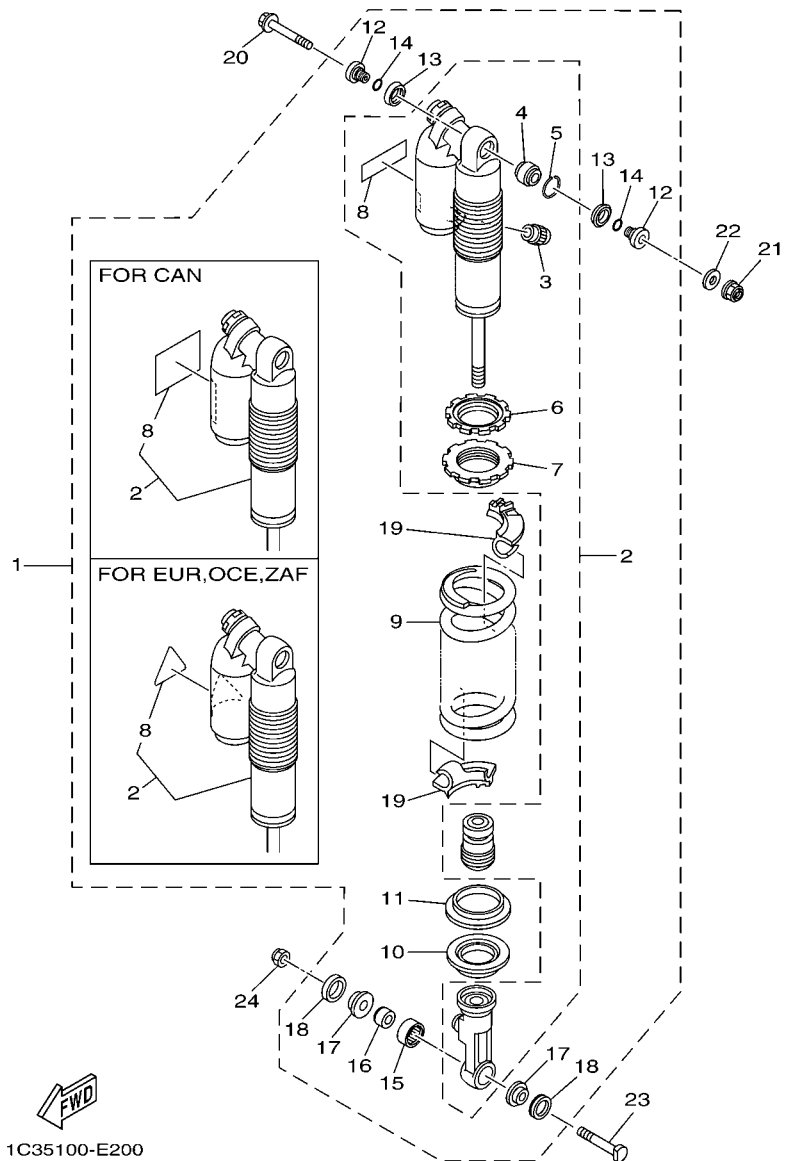

1C35100-E200

REF. NO.	PART NO.	DESCRIPTION	1P85	1P86	1P87	1P88	REMARKS
17	5MV-22253-00	.COLLAR, DISTANCE	2	2	2	2	
18	5NY-22475-00	.SEAL, DUST	2	2	2	2	
19	1C3-22565-00	.SPRING SEAT	2	2	2	2	
20	5XE-22242-00	BOLT 2	1	1	1	1	
21	95607-10200	NUT, U FLANGE	1	1	1	1	
22	92907-10200	WASHER, PLAIN	1	1	1	1	
23	5NY-22241-00	BOLT 1	1	1	1	1	
24	90185-10060	NUT, SELF-LOCKING	1	1	1	1	

FIG. 21 STEERING

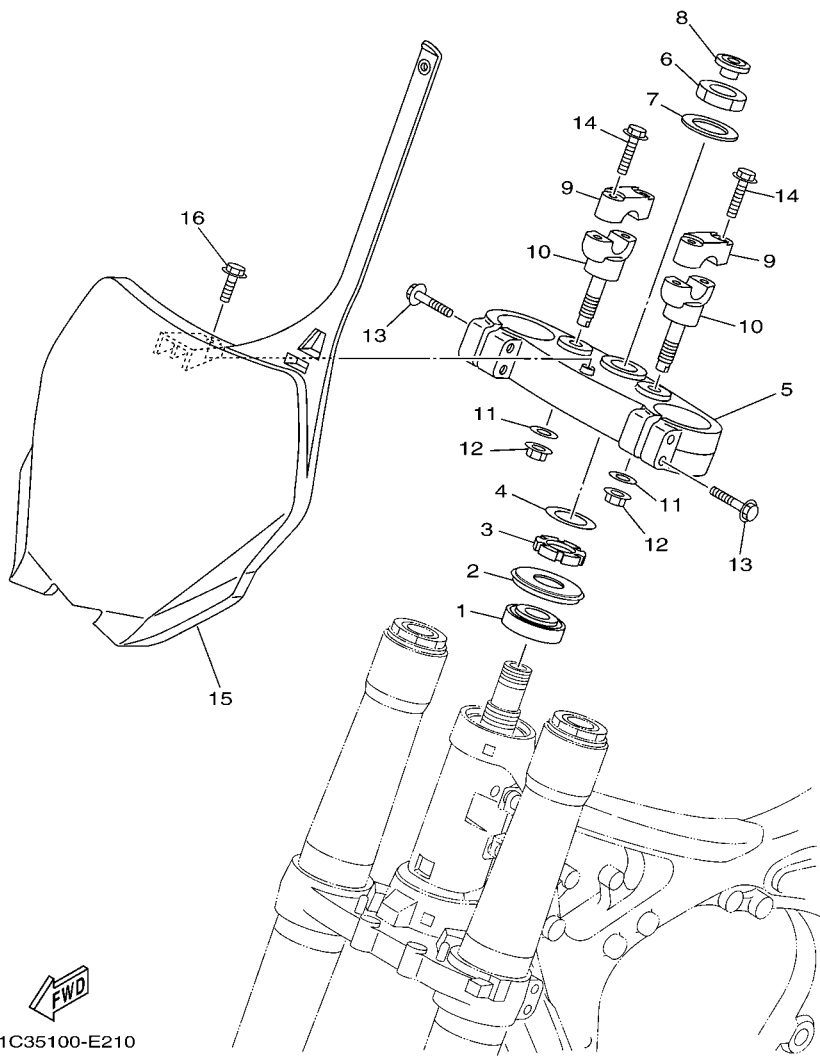

REF. NO.	PART NO.	DESCRIPTION	1P85	1P86	1P87	1P88	REMARKS
1	93332-00068	BEARING	1	1	1	1	
2	4EW-23416-00	COVER, BALL RACE 2	1	1	1	1	
3	90179-28003	NUT	1	1	1	1	
4	90201-286K9	WASHER, PLATE	1	1	1	1	
5	1C3-23435-50	CROWN, HANDLE	1	1	1	1	
6	90170-24003	NUT	1	1	1	1	
7	90201-24016	WASHER, PLATE	1	1	1	1	
8	5TJ-2319U-00	CAP	1	1	1	1	
9	1C3-23441-50	HOLDER, HANDLE UPPER	2	2	2	2	
10	1C3-23442-50	HOLDER, HANDLE LOWER	2	2	2	2	
11	90201-12028	WASHER, PLATE	2	2	2	2	
12	95602-12200	NUT, SELF-LOCKING	2	2	2	2	
13	95024-08040	BOLT, FLANGE	4	4	4	4	
14	95024-08035	BOLT, FLANGE	4	4	4	4	
15	1C3-23485-50	PLATE, NUMBER	1	1	1	1	
16	90119-06217	BOLT, WITH WASHER	1	1	1	1	

FIG. 22 FRONT FORK

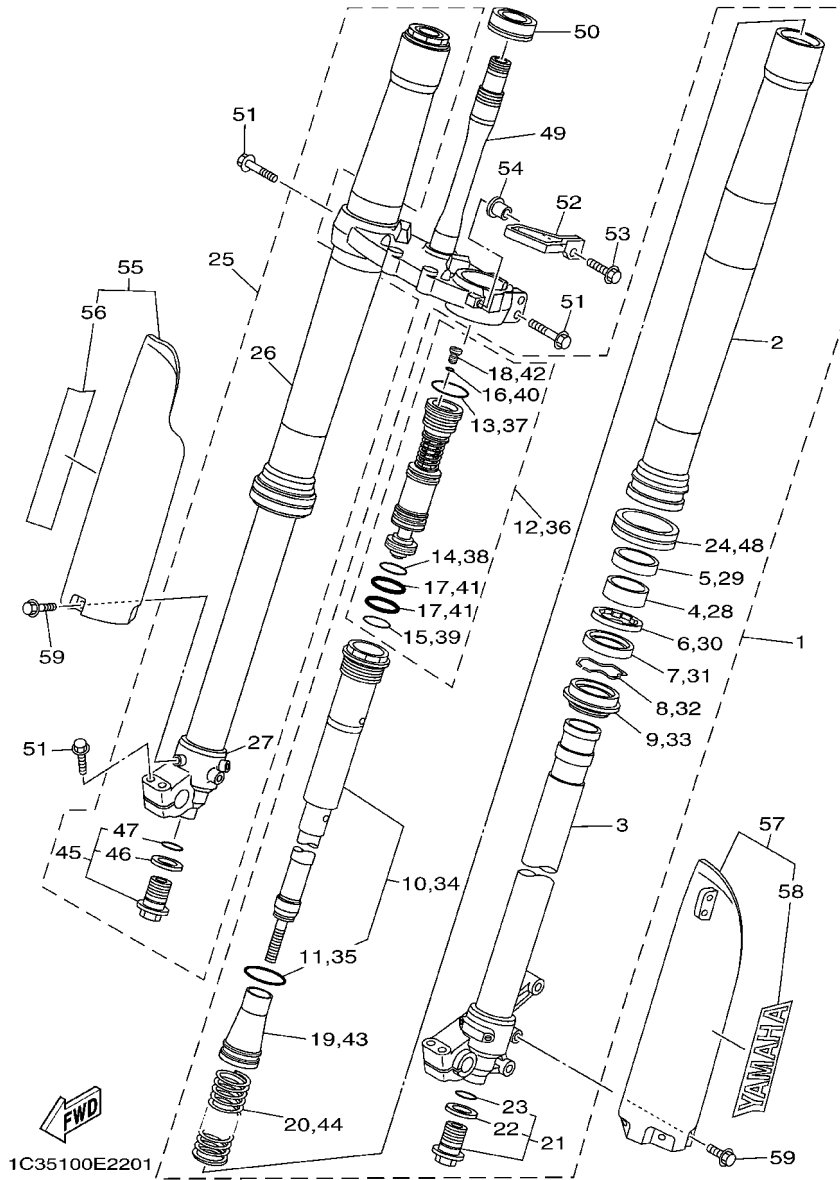

REF. NO.	PART NO.	DESCRIPTION	1P85	1P86	1P87	1P88	REMARKS
1	1P8-23102-50	FRONT FORK ASSY (L.H)	1		1	1	
	1P8-23102-60	FRONT FORK ASSY (L.H)		1			
2	1C3-23136-M0	.TUBE, OUTER (RIGHT)	1	1	1	1	
3	1C3-23120-M0	.INNER TUBE COMP.2	1	1	1	1	
4	5XE-23171-L0	.PISTON, FRONT FORK	1	1	1	1	
5	5XE-23125-L0	.METAL, SLIDE 1	1	1	1	1	
6	5XE-23146-L0	.WASHER, OIL SEAL	1	1	1	1	
7	1C3-23145-M0	.OIL SEAL	1	1	1	1	
8	5XE-23153-L0	.RING, SNAP	1	1	1	1	
9	5XE-23144-L0	.SEAL, DUST	1	1	1	1	
10	1C3-23170-N0	.CYLINDER COMP., FRONT FORK	1		1	1	
	1P8-23170-L0	.CYLINDER COMP., FRONT FORK		1			
11	1C3-23147-L0	..O-RING	1	1	1	1	
	1C3-2316A-N0	.VALVE COMP.	1		1	1	
	1P8-2316A-M0	.VALVE COMP.		1			
13	1C3-23188-L0	..O-RING	1	1	1	1	
14	1C3-23188-N0	..O-RING	1	1	1	1	
15	1C3-23188-P0	..O-RING	1	1	1	1	
16	1C3-23188-R0	..O-RING	1	1	1	1	
17	1AE-23147-00	..O-RING	2	2	2	2	
18	1C3-23190-L0	..AIR VALVE COMP.	1	1	1	1	
19	1C3-23142-L0	.SEAT, SPRING UPPER	1	1	1	1	
20	1P8-23141-M0	.SPRING, FRONT FORK(K=4.2N/MM)	1	1	1	1	
21	1C3-23111-L0	.BOLT, CAP	1	1	1	1	
22	2HH-23158-L0	..GASKET	1	1	1	1	
23	276-23114-00	..GASKET	1	1	1	1	
24	1C3-2314F-M0	.PROTECTOR GUIDE COMP., 1	1	1	1	1	

FIG. 22 FRONT FORK

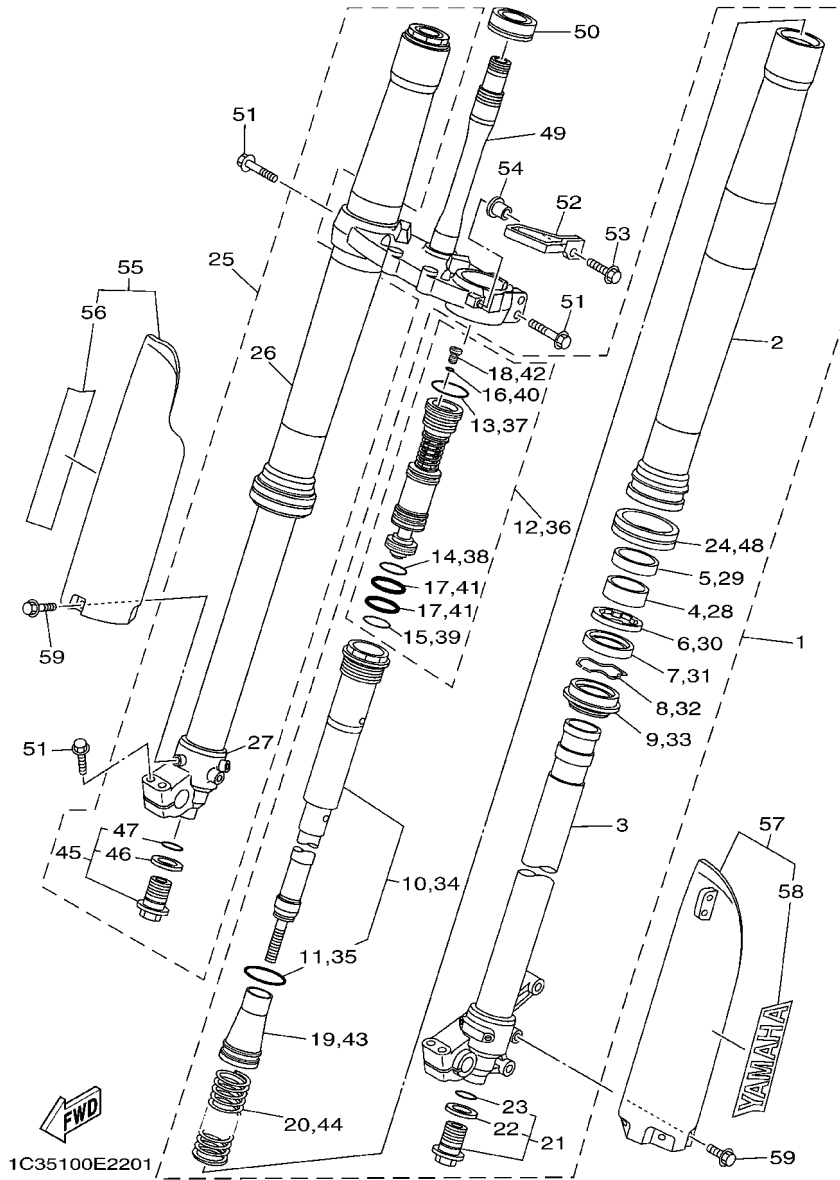

REF. NO.	PART NO.	DESCRIPTION	1P85	1P86	1P87	1P88	REMARKS
25	1P8-23103-50	FRONT FORK ASSY (R.H)	1		1	1	
	1P8-23103-60	FRONT FORK ASSY (R.H)		1			
26	1C3-23136-M0	.TUBE, OUTER (RIGHT)	1	1	1	1	
27	1C3-23110-M0	.INNER TUBE COMP.1	1	1	1	1	
28	5XE-23171-L0	.PISTON, FRONT FORK	1	1	1	1	
29	5XE-23125-L0	.METAL, SLIDE 1	1	1	1	1	
30	5XE-23146-L0	.WASHER, OIL SEAL	1	1	1	1	
31	1C3-23145-M0	.OIL SEAL	1	1	1	1	
32	5XE-23153-L0	.RING, SNAP	1	1	1	1	
33	5XE-23144-L0	.SEAL, DUST	1	1	1	1	
34	1C3-23170-N0	.CYLINDER COMP., FRONT FORK	1		1	1	
	1P8-23170-L0	.CYLINDER COMP., FRONT FORK		1			
35	1C3-23147-L0	..O-RING	1	1	1	1	
36	1C3-2316A-N0	.VALVE COMP.	1		1	1	
	1P8-2316A-M0	.VALVE COMP.		1			
37	1C3-23188-L0	..O-RING	1	1	1	1	
38	1C3-23188-N0	..O-RING	1	1	1	1	
39	1C3-23188-P0	..O-RING	1	1	1	1	
40	1C3-23188-R0	..O-RING	1	1	1	1	
41	1AE-23147-00	..O-RING	2	2	2	2	
42	1C3-23190-L0	..AIR VALVE COMP.	1	1	1	1	
43	1C3-23142-L0	.SEAT, SPRING UPPER	1	1	1	1	
44	1P8-23141-M0	.SPRING, FRONT FORK(K=4.2N/MM)	1	1	1	1	
45	1C3-23111-L0	.BOLT, CAP	1	1	1	1	
46	2HH-23158-L0	..GASKET	1	1	1	1	
47	276-23114-00	..GASKET	1	1	1	1	
48	1C3-2314F-M0	.PROTECTOR GUIDE COMP., 1	1	1	1	1	

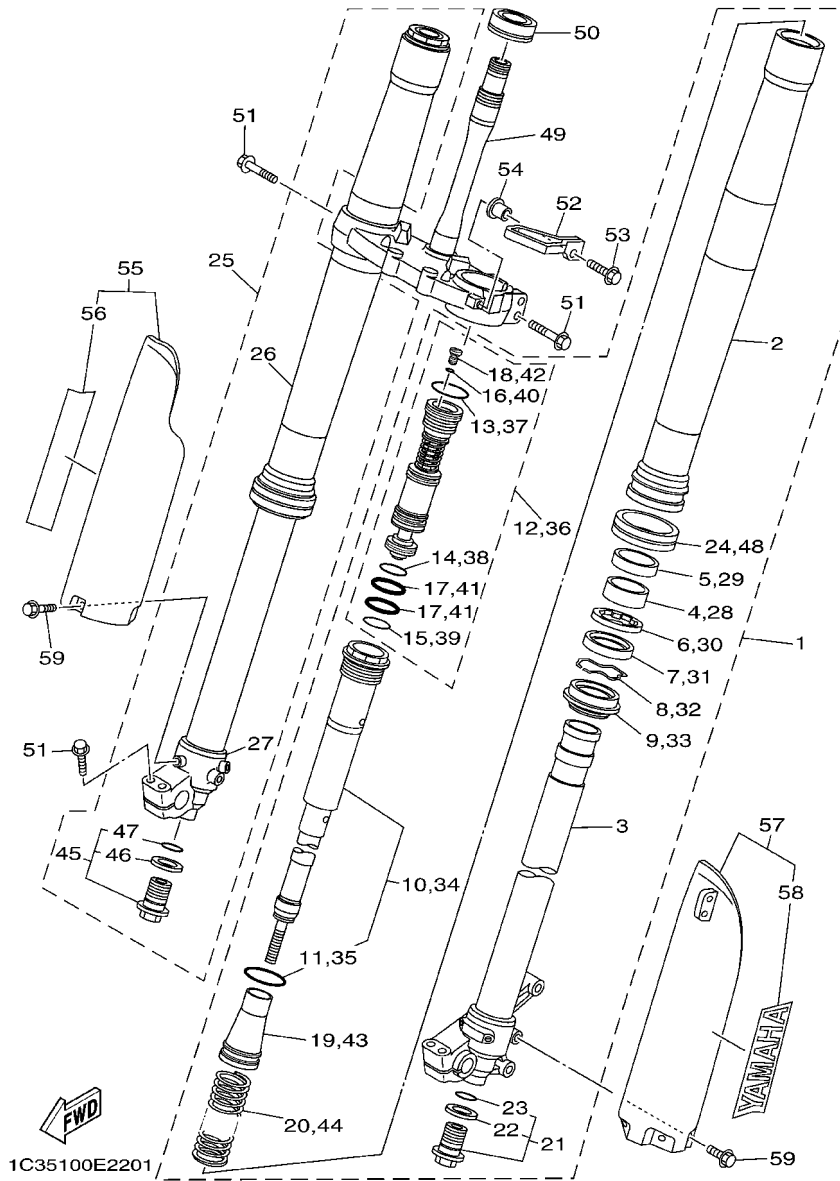

1C35100E2201

FIG. 22 FRONT FORK

REF. NO.	PART NO.	DESCRIPTION	1P85	1P86	1P87	1P88	REMARKS
49	1P8-23340-M0	UNDER BRACKET COMP.	1	1	1	1	
50	93332-00081	BEARING	1	1	1	1	
51	95024-08040	BOLT, FLANGE	8	8	8	8	
52	5XE-23389-00	GUIDE, CABLE	1	1	1	1	
53	95024-06020	BOLT, FLANGE	1	1	1	1	
54	90387-06104	COLLAR	1	1	1	1	
55	1C3-2314J-10	PROTECTOR COMP., 2	1	1	1	1	
56	4XL-2153A-10	.EMBLEM, YAMAHA	1	1	1	1	
57	1C3-2314H-10	PROTECTOR COMP., 1	1	1	1	1	
58	4XL-2153A-10	.EMBLEM, YAMAHA	1	1	1	1	
59	3SP-23356-L0	BOLT 2	6	6	6	6	

FIG. 23 FUEL TANK

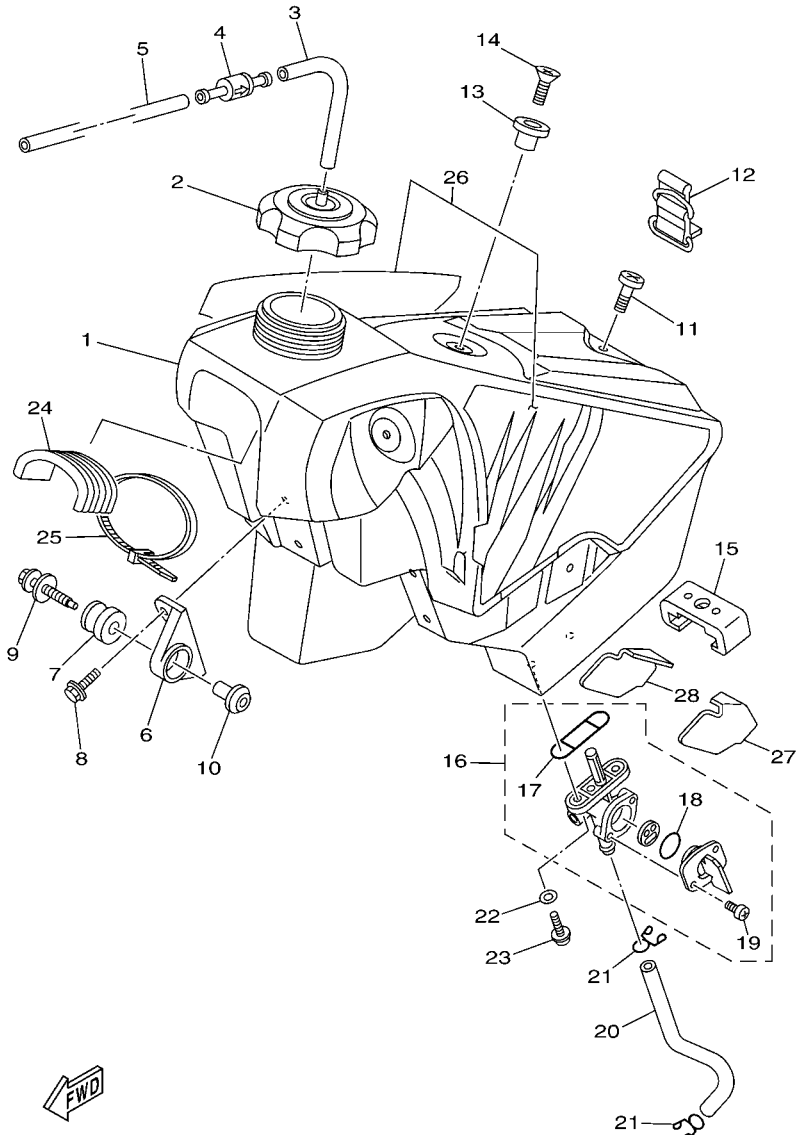

1C35100-E230

REF. NO.	PART NO.	DESCRIPTION	1P85	1P86	1P87	1P88	REMARKS
1	1C3-24110-50	FUEL TANK COMP.	1	1	1	1	
2	5NY-24610-00	CAP ASSY	1	1	1	1	
3	90445-09220	HOSE (L30)	1	1	1	1	
4	3XJ-24380-00	PIPE JOINT ASSY	1	1	1	1	
5	90445-09025	HOSE	1	1	1	1	
6	5XE-24144-00	HOLDER, DAMPER	2	2	2	2	
7	90480-18549	GROMMET	2	2	2	2	
8	95027-06016	BOLT, FLANGE	4	4	4	4	
9	5XE-24176-00	BOLT 1	2	2	2	2	
10	5NY-24186-00	WASHER, SPECIAL	2	2	2	2	
11	98907-06025	SCREW, BIND	1	1	1	1	
12	3SP-24173-00	BAND, TANK FITTING 1	1	1	1	1	
13	4EW-2412F-00	BRACKET, SEAT	1	1	1	1	
14	98707-06025	SCREW, FLAT HEAD	1	1	1	1	
15	1C3-24181-00	DAMPER, LOCATING 1	1	1	1	1	
16	3JD-24500-10	FUEL COCK ASSY 1	1	1	1	1	
17	4X8-24512-00	.O-RING	1	1	1	1	
18	3AJ-24534-01	.SEAL, COCK	1	1	1	1	
19	98507-03008	.SCREW, PAN HEAD	2	2	2	2	
20	90445-111J0	HOSE (L145)	1	1	1	1	
21	90467-100A1	CLIP	2	2	2	2	
22	90202-05193	WASHER, PLATE	2	2	2	2	
23	90149-06011	SCREW	2	2	2	2	
24	1P8-24182-00	DAMPER, LOCATING 2	1	1	1	1	
25	90465-13275	CLAMP	1	1	1	1	
26	1C3-24240-10	GRAPHIC SET	1	1	1	1	
27	1C3-24183-00	DAMPER, LOCATING 3	1	1	1	1	

FIG. 23 FUEL TANK

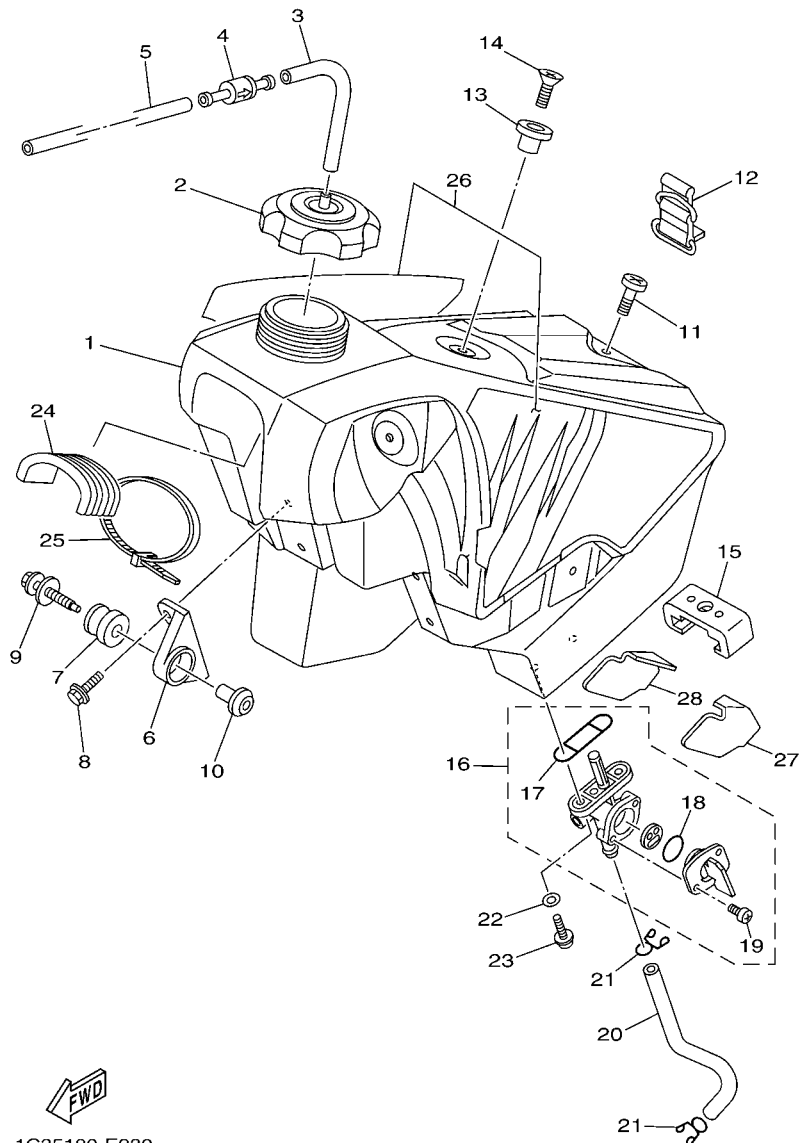

1C35100-E230

REF. NO.	PART NO.	DESCRIPTION	1P85	1P86	1P87	1P88	REMARKS
28	1C3-24184-00	DAMPER, LOCATING 4	1	1	1	1	

FIG. 24 SEAT

REF. NO.	PART NO.	DESCRIPTION	1P85	1P86	1P87	1P88	REMARKS
1	1C3-24770-50	SEMI-DOUBLE SEAT ASSY	1	1	1	1	
2	1C3-2470F-50	.SEAT COVER COMP.	1	1	1	1	
3	5NY-24728-10	.BRACKET, SEAT	2	2	2	2	
4	97307-06012	.BOLT	4	4	4	4	
5	92907-06100	.WASHER, SPRING	4	4	4	4	

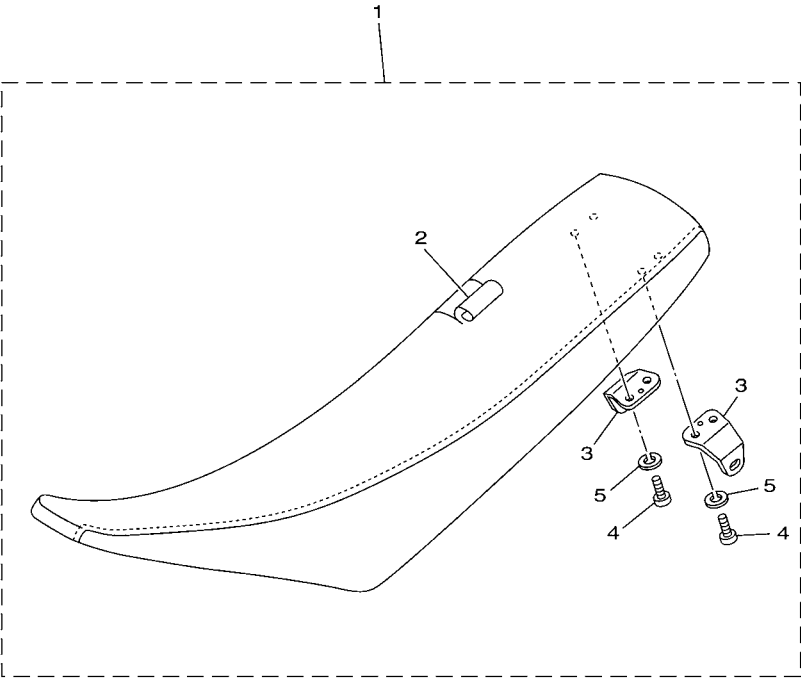

5NY1100-A241

FIG. 25 FRONT WHEEL

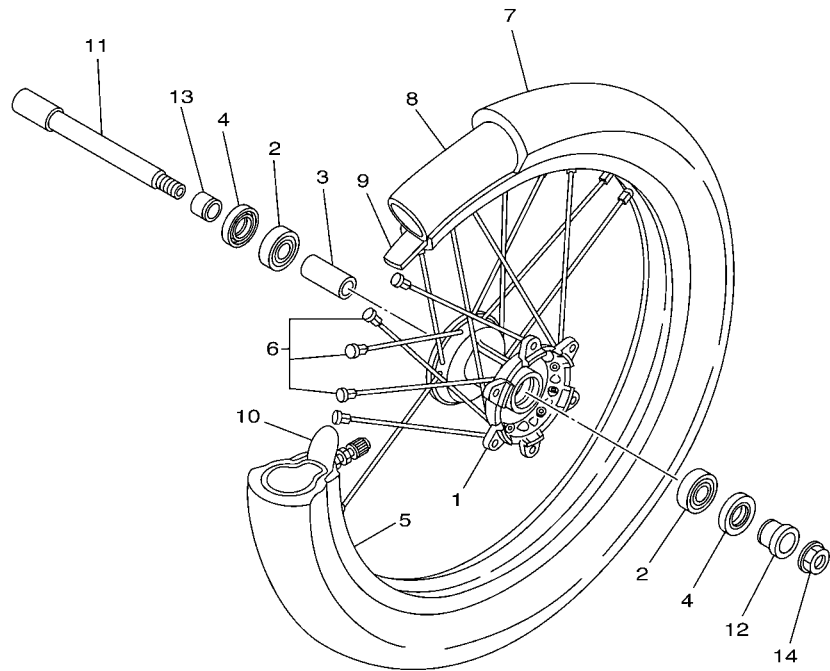

REF. NO.	PART NO.	DESCRIPTION	1P85	1P86	1P87	1P88	REMARKS
1	5NY-25111-00	HUB, FRONT	1	1	1	1	
2	93306-90409	BEARING	2	2	2	2	
3	5NY-25117-00	SPACER, BEARING	1	1	1	1	
4	93102-26468	OIL SEAL	2	2	2	2	
5	94416-21018	RIM (1.60-21)	1	1	1	1	
6	5NY-25104-00	SPOKE SET, FRONT	1	1	1	1	
7	94108-21015	TIRE (80/100-21 51M D739FA)	1			1	UR DUNLOP FOR USA
	94108-2112Y	TIRE (80/100-21 51M D755F)	1	1			UR DUNLOP FOR CAN
	94108-21012	TIRE(80/100-21 51M M601)			1		BRIDGESTONE
8	94227-21101	TUBE (80/100-21 M/C TR4)	1	1		1	DUNLOP
	94209-21229	TUBE (80/100-21 M/C TR4)			1		BRIDGESTONE
9	94309-21161	BAND, RIM (1.60-21)	1	1		1	DUNLOP
	94330-21084	BAND,RIM (1.60-21)			1		BRIDGESTONE
10	5SF-25394-00	SPACER, BEAD	1	1	1	1	
11	1C3-25181-10	AXLE, WHEEL	1	1	1	1	
12	5NY-25183-00	COLLAR, WHEEL	1	1	1	1	
13	5NY-25186-00	COLLAR, WHEEL	1	1	1	1	
14	90179-16003	NUT	1	1	1	1	

1C31100-D250

D12

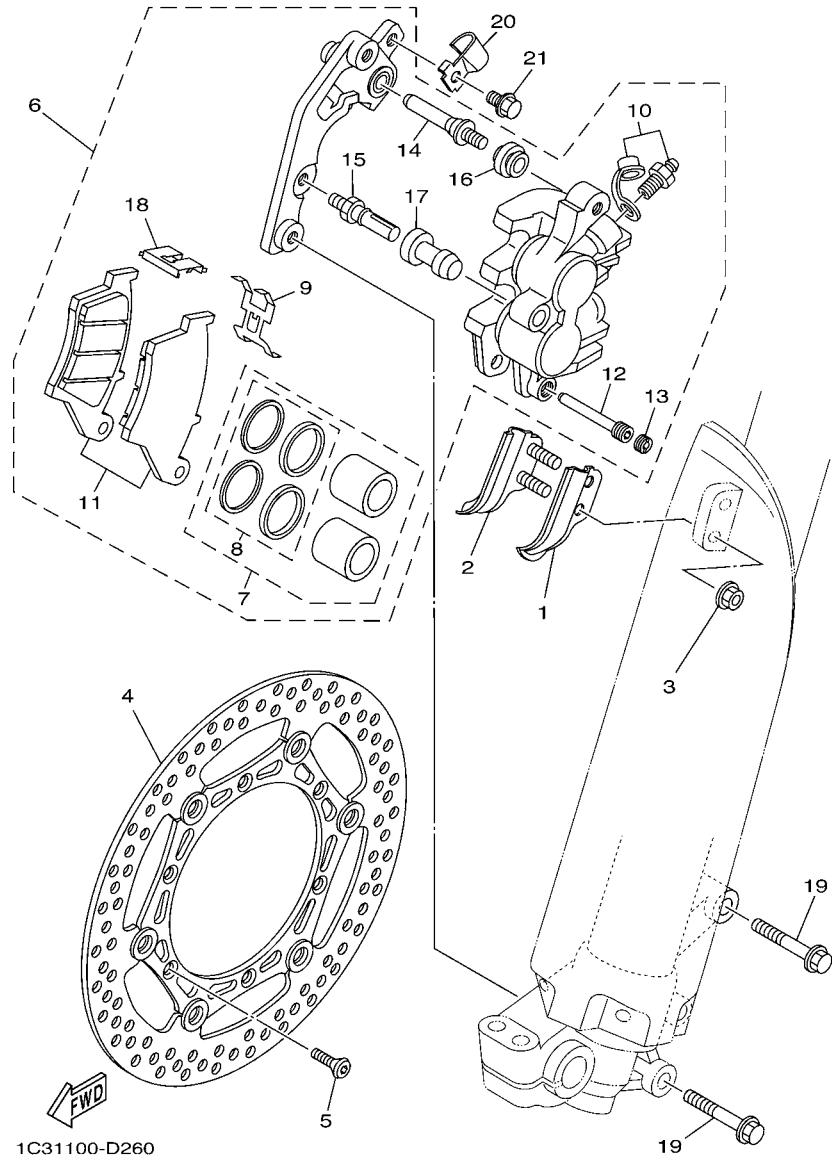
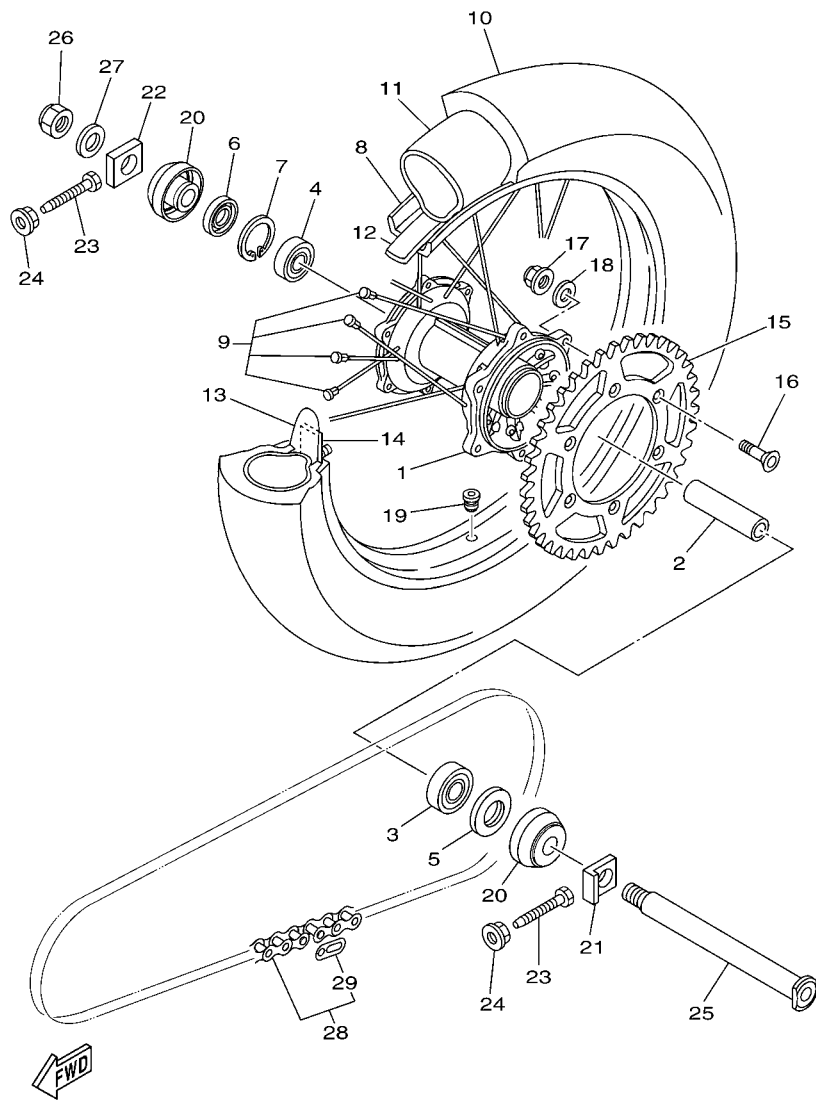

FIG. 26 FRONT BRAKE CALIPER

REF. NO.	PART NO.	DESCRIPTION	1P85	1P86	1P87	1P88	REMARKS
1	1C3-23466-50	CLAMP	1	1	1	1	
2	1C3-23467-50	CLAMP	1	1	1	1	
3	95702-06500	NUT, FLANGE	2	2	2	2	
4	5MV-2581T-00	DISK BRAKE ASSY	1	1	1	1	
5	90149-06327	SCREW	6	6	6	6	
6	1C3-2580T-00	CALIPER ASSY (LEFT)	1	1	1	1	
7	5UN-W0057-00	.PISTON ASSY, CALIPER	1	1	1	1	
8	3JD-W0047-00	..CALIPER SEAL KIT	1	1	1	1	
9	5DH-25919-00	.SUPPORT, PAD	1	1	1	1	
10	1UY-W0048-50	.BLEED SCREW KIT	1	1	1	1	
11	5MV-W0045-01	.BRAKE PAD KIT	1	1	1	1	
12	5DH-25933-00	.PIN, PAD	1	1	1	1	
13	5DH-25916-00	.PLUG	1	1	1	1	
14	3SP-25926-51	.BOLT	1	1	1	1	
15	3SP-25914-51	.PIN, SLIDE	1	1	1	1	
16	3JD-25917-00	.BOOT, CALIPER	1	1	1	1	
17	1UY-25937-51	.BOOT 2	1	1	1	1	
18	5DH-25849-00	.RETAINER, CALIPER	1	1	1	1	
19	90105-08077	BOLT, FLANGE	2	2	2	2	
20	1C3-25875-50	HOLDER, BRAKE HOSE 1	1	1	1	1	
21	95024-06010	BOLT, FLANGE	1	1	1	1	

FIG. 27 REAR WHEEL



1C35100-E270

REF. NO.	PART NO.	DESCRIPTION	1P85	1P86	1P87	1P88	REMARKS
1	5ET-25311-00	HUB, REAR	1	1	1	1	
2	5ET-25317-00	SPACER, BEARING	1	1	1	1	
3	93306-27212	BEARING	1	1	1	1	
4	93306-07202	BEARING	1	1	1	1	
5	93106-30001	OIL SEAL	1	1	1	1	
6	93106-30045	OIL SEAL	1	1	1	1	
7	99009-45500	CIRCLIP	1	1	1	1	
8	94421-19003	RIM (2.15-19)	1	1	1	1	
9	5HD-25304-00	SPOKE SET, REAR	1	1	1	1	
10	94111-19015	TIRE (110/90-19 62M D756)	1			1	UR DUNLOP FOR USA
	94111-1913A	TIRE (110/90-19 62M D755)	1	1			UR DUNLOP FOR CAN
	94111-19011	TIRE (110/90-19 62M M602)				1	BRIDGESTONE
11	94211-19273	TUBE (110/90-19 M/C TR4)	1	1		1	DUNLOP
	94211-19274	TUBE (110/90-19 M/C TR4)				1	BRIDGESTONE
12	94311-19155	BAND, RIM (2.15-19)	1	1		1	DUNLOP
	94321-19157	BAND, RIM (2.15-19)				1	BRIDGESTONE
13	3JE-25394-00	SPACER, BEAD	1	1	1	1	
14	4XM-25364-00	DAMPER	1	1	1	1	
15	1C3-25450-00	SPROCKET, DRIVEN (50T)	1	1	1	1	STD
	1C3-25447-00	SPROCKET, DRIVEN (47T)	1	1	1	1	AP
	1C3-25448-00	SPROCKET, DRIVEN (48T)	1	1	1	1	AP
	1C3-25449-00	SPROCKET, DRIVEN (49T)	1	1	1	1	AP
	1C3-25450-00	SPROCKET, DRIVEN (50T)	1	1	1	1	AP
	1C3-25451-00	SPROCKET, DRIVEN (51T)	1	1	1	1	AP
	1C3-25452-00	SPROCKET, DRIVEN (52T)	1	1	1	1	AP
16	90109-08078	BOLT	6	6	6	6	
17	90185-08008	NUT, SELF-LOCKING	6	6	6	6	

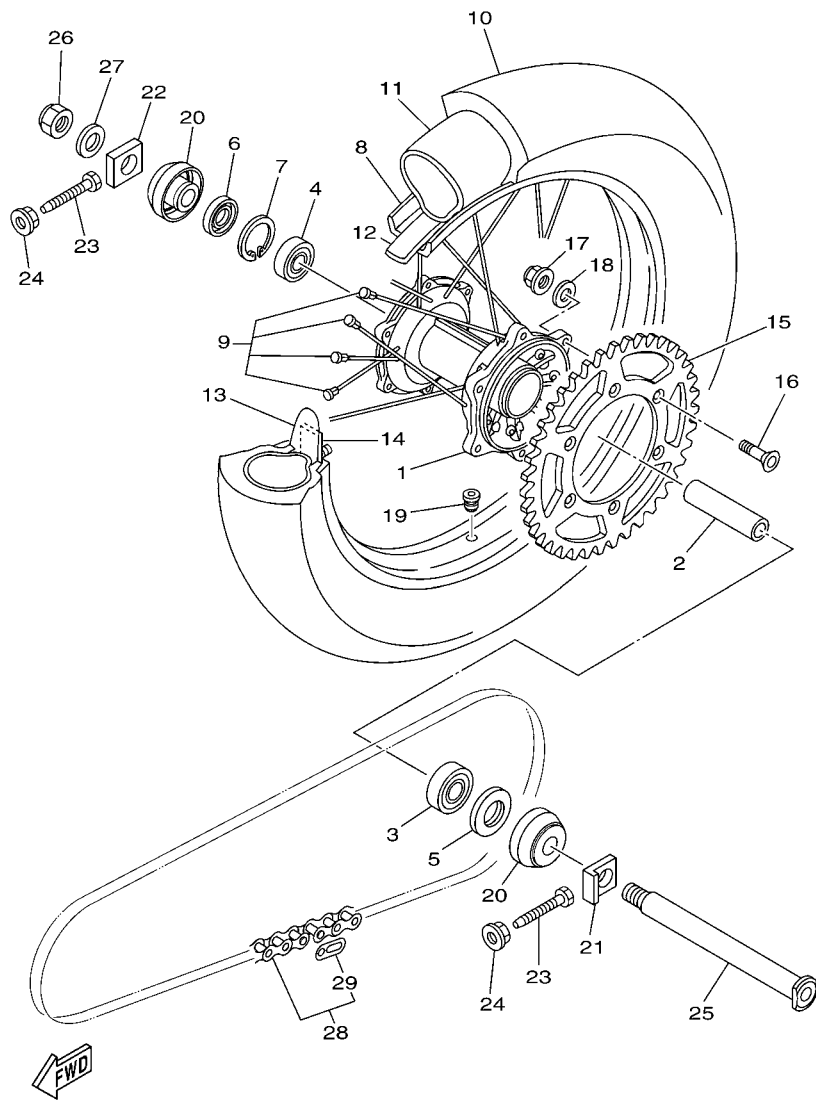

1C35100-E270

FIG. 27 REAR WHEEL

REF. NO.	PART NO.	DESCRIPTION	1P85	1P86	1P87	1P88	REMARKS
18	90201-08048	WASHER, PLATE	6	6	6	6	
19	90480-08608	GROMMET	1	1	1	1	
20	5TJ-2530S-80	COLLAR ASSY	2	2	2	2	
21	1C3-25388-50	PULLER, CHAIN 1	1	1	1	1	
22	1C3-25389-00	PULLER, CHAIN 2	1	1	1	1	
23	90101-08006	BOLT	2	2	2	2	
24	90179-08656	NUT	2	2	2	2	
25	1C3-25381-10	AXLE, WHEEL	1	1	1	1	
26	90185-20002	NUT, SELF-LOCKING	1	1	1	1	
27	90201-20020	WASHER, PLATE	1	1	1	1	
28	9Y581-92113	CHAIN (DID 520D 114L)	1	1	1	1	
29	94681-68001	.JOINT,CHAIN (DID 520DM-RJ)	1	1	1	1	

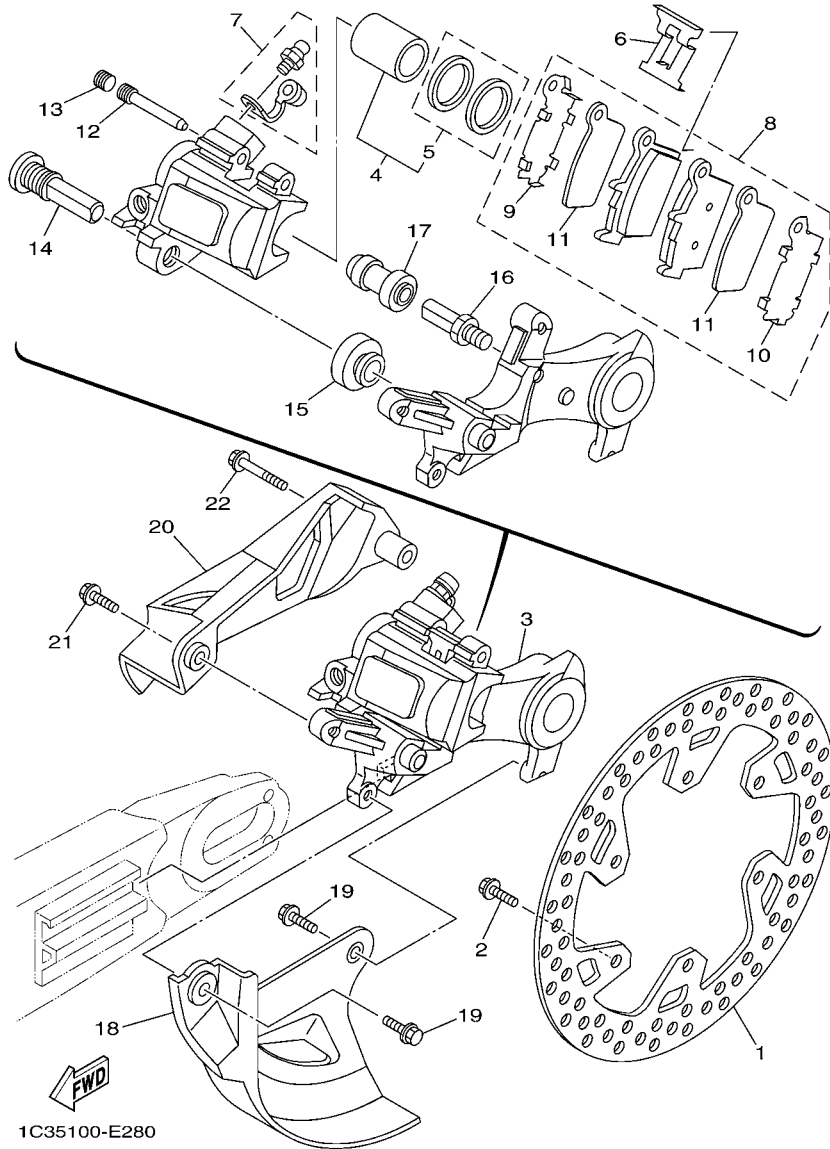
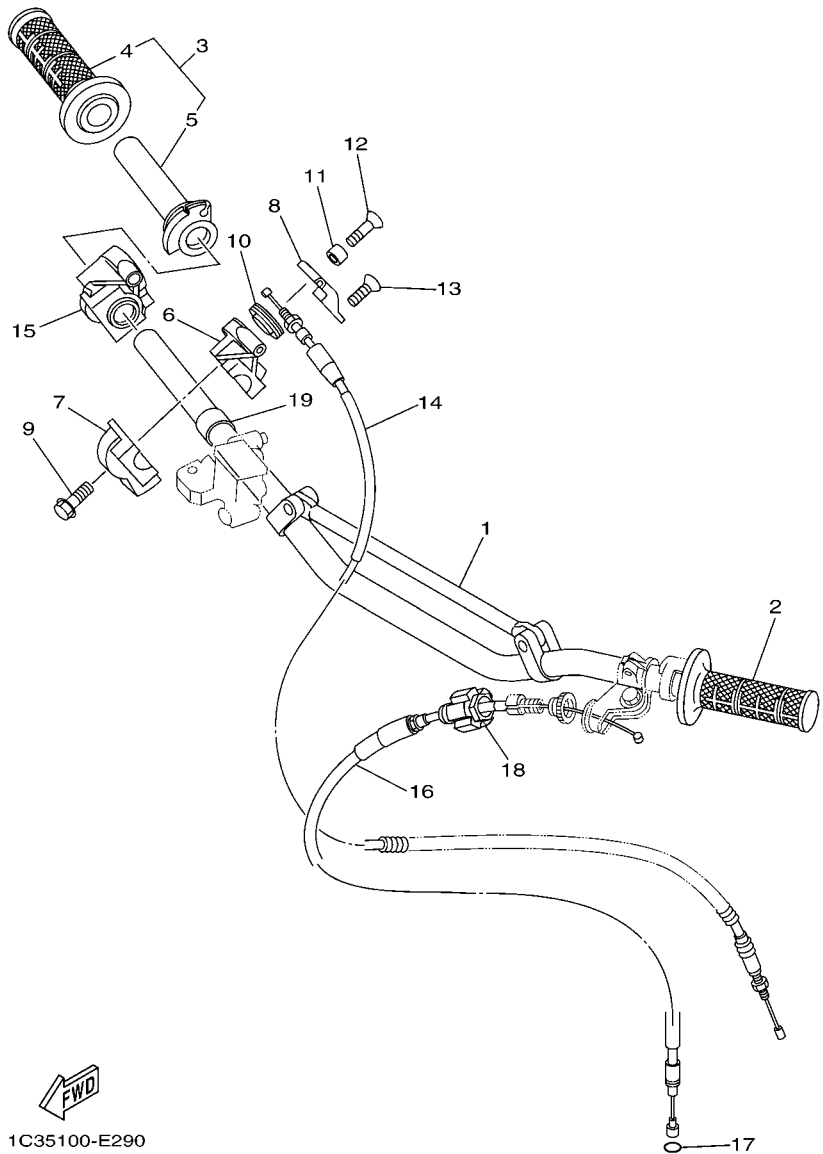

FIG. 28 REAR BRAKE CALIPER

REF. NO.	PART NO.	DESCRIPTION	1P85	1P86	1P87	1P88	REMARKS
1	5NY-2582W-00	DISK, REAR BRAKE 2	1	1	1	1	
2	90109-065G4	BOLT	6	6	6	6	
3	1C3-2580W-60	CALIPER ASSY, REAR 2	1	1	1	1	
4	5UN-W0057-50	.PISTON ASSY, CALIPER	1	1	1	1	
5	5UN-W0047-50	..CALIPER SEAL KIT	1	1	1	1	
6	5DH-25919-50	..SUPPORT, PAD	1	1	1	1	
7	1UY-W0048-50	.BLEED SCREW KIT	1	1	1	1	
8	1C3-W0046-10	.BRAKE PAD KIT 2	1	1	1	1	
9	5UN-25828-60	..SHIM, CALIPER	1	1	1	1	
10	5UN-25827-60	..SHIM, CALIPER	1	1	1	1	
11	5UN-22898-60	..INSULATOR, HEAT	2	2	2	2	
12	8CR-25924-00	.PIN, PAD	1	1	1	1	
13	5DH-25916-00	.PLUG	1	1	1	1	
14	5DH-25914-50	.PIN, SLIDE	1	1	1	1	
15	3JD-25917-00	.BOOT, CALIPER	1	1	1	1	
16	5UN-25914-00	.PIN, SLIDE	1	1	1	1	
17	1UY-25937-51	.BOOT 2	1	1	1	1	
18	1C3-25718-50	PROTECTOR, DISK BRAKE	1	1	1	1	
19	95022-06012	BOLT, FLANGE	2	2	2	2	
20	1C3-27491-50	PROTECTOR	1	1	1	1	
21	95024-06016	BOLT, FLANGE	1	1	1	1	
22	95024-06030	BOLT, FLANGE	1	1	1	1	



1C35100-E290

FIG. 29 STEERING HANDLE & CABLE

REF. NO.	PART NO.	DESCRIPTION	1P85	1P86	1P87	1P88	REMARKS
1	1C3-26111-00	HANDLEBAR	1	1	1	1	
2	4GY-26241-00	GRIP	1	1	1	1	
3	4XM-26240-00	GRIP ASSY	1	1	1	1	
4	4GY-26242-00	.GRIP (RIGHT)	1	1	1	1	
5	4XM-26243-00	.TUBE, THROTTLE GUIDE	1	1	1	1	
6	4SS-26281-00	CAP, GRIP UPPER	1	1	1	1	
7	4SS-26282-10	CAP, GRIP LOWER	1	1	1	1	
8	4SS-2628H-00	CAP, WIRE	1	1	1	1	
9	95027-06025	BOLT, FLANGE	2	2	2	2	
10	5NY-26273-00	ROTOR	1	1	1	1	
11	4SS-26259-00	COLLAR	1	1	1	1	
12	4SS-26256-00	SCREW, GRIP END	1	1	1	1	
13	4SS-2632G-00	SCREW	1	1	1	1	
14	1P8-26311-50	CABLE, THROTTLE 1	1	1	1	1	
15	4SS-26287-01	COVER, CAP GRIP	1	1	1	1	
16	1P8-26335-50	CABLE, CLUTCH	1	1	1	1	
17	93210-06001	O-RING	1	1	1	1	
18	1C3-26342-50	BOOT, CABLE	1	1	1	1	
19	90387-227H7	COLLAR	1	1	1	1	

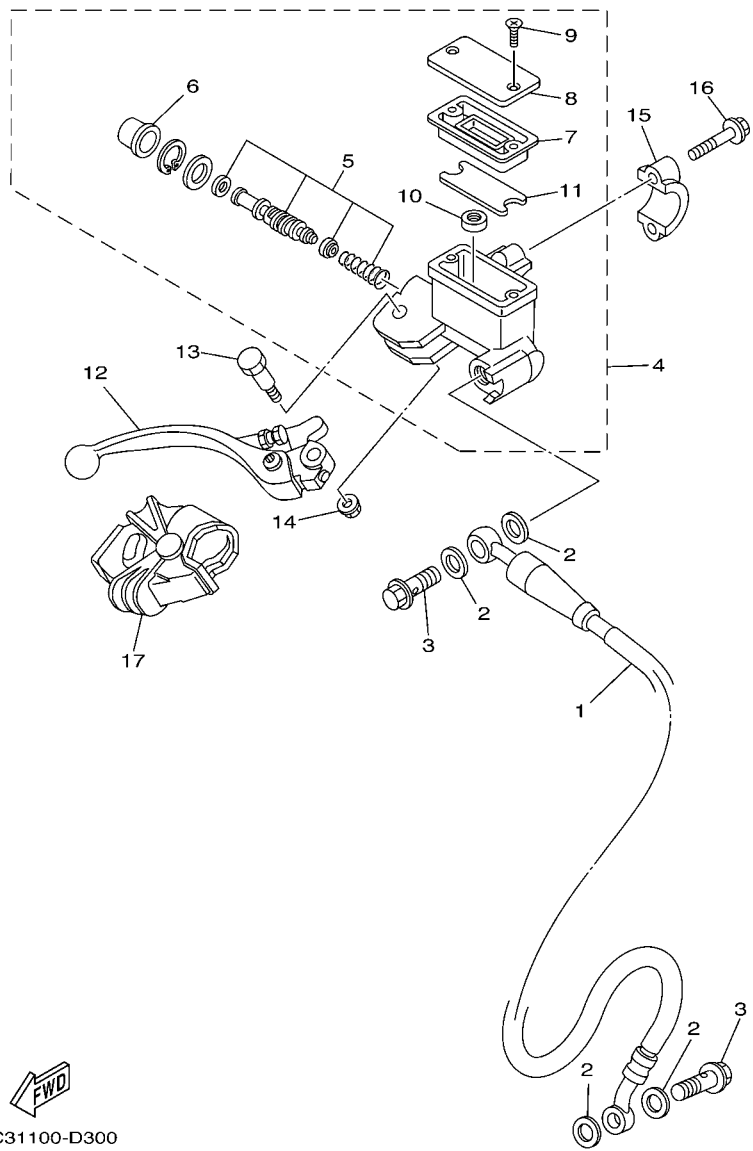

1C31100-D300

FIG. 30 FRONT MASTER CYLINDER

REF. NO.	PART NO.	DESCRIPTION	1P85	1P86	1P87	1P88	REMARKS
1	1C3-25872-50	HOSE, BRAKE 1	1	1	1	1	
2	90201-10118	WASHER, PLATE	4	4	4	4	
3	90401-10172	BOLT, UNION	2	2	2	2	
4	5XE-W2587-00	MASTER CYLINDER SUB ASSY	1	1	1	1	
5	5NY-W0041-00	.CYLINDER KIT, MASTER	1	1	1	1	
6	5NY-25868-00	.BOOT, MASTER CYLINDER	1	1	1	1	
7	5XE-25854-00	.DIAPHRAGM, RESERVOIR	1	1	1	1	
8	5MV-25852-01	.CAP, RESERVOIR	1	1	1	1	
9	98706-04012	.SCREW, FLAT HEAD	2	2	2	2	
10	5CG-25715-00	.SEPARATOR ASSY	1	1	1	1	
11	5XE-25853-00	.FLOAT, RESERVOIR	1	1	1	1	
12	5MV-83922-00	LEVER 2	1	1	1	1	
13	5MV-2589F-00	BOLT, LEVER	1	1	1	1	
14	95701-06500	NUT, FLANGE	1	1	1	1	
15	5MV-25867-00	BRACKET, MASTER CYLINDER	1	1	1	1	
16	5MV-25833-00	BOLT, FITTING	2	2	2	2	
17	5NY-26372-00	COVER, HANDLE LEVER 1	1	1	1	1	

FIG. 31 STAND & FOOTREST

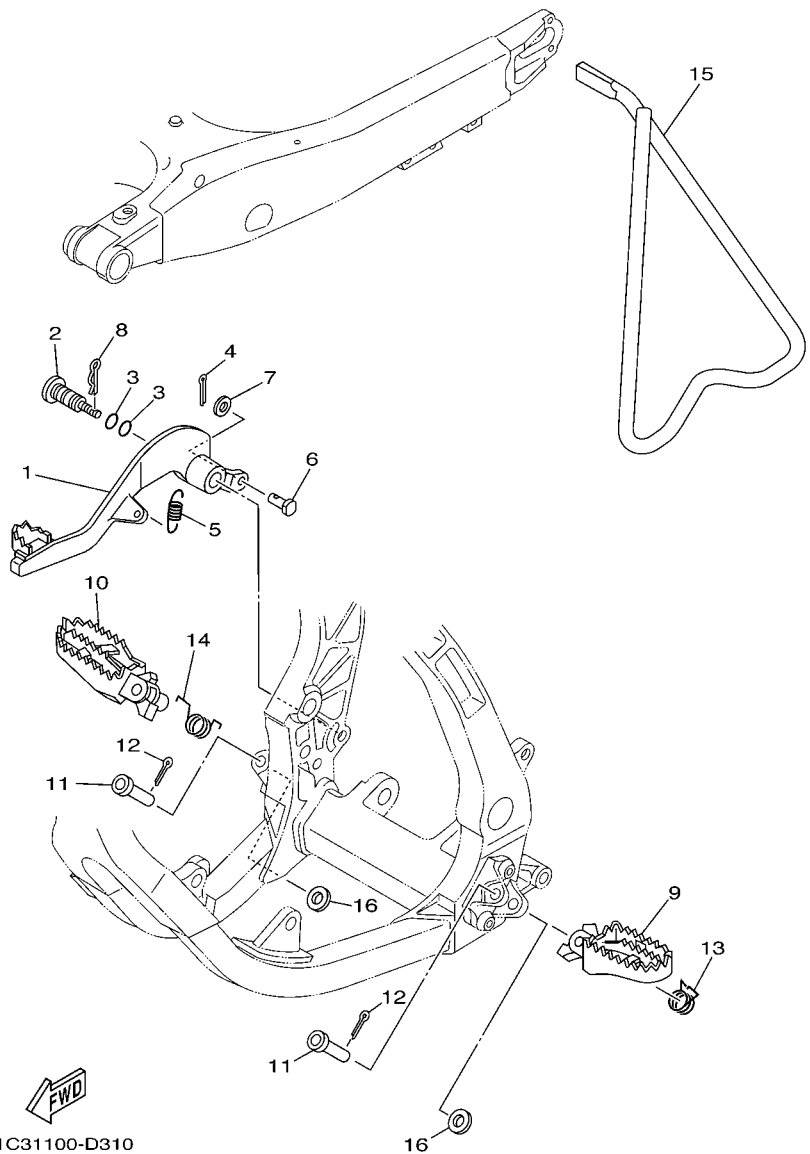

REF. NO.	PART NO.	DESCRIPTION	1P85	1P86	1P87	1P88	REMARKS
1	1C3-27200-10	PEDAL, BRAKE	1	1	1	1	
2	1C3-27217-10	BOLT	1	1	1	1	
3	93210-11073	O-RING	2	2	2	2	
4	91402-20012	PIN, COTTER	1	1	1	1	
5	90506-16007	SPRING, TENSION	1	1	1	1	
6	90240-08120	PIN, CLEVIS	1	1	1	1	
7	90201-08044	WASHER, PLATE	1	1	1	1	
8	90468-16001	CLIP	1	1	1	1	
9	5XE-27411-01	FOOTREST 1	1	1	1	1	
10	5XE-27421-01	FOOTREST 2	1	1	1	1	
11	90240-10004	PIN, CLEVIS	2	2	2	2	
12	91402-25015	PIN, COTTER	2	2	2	2	
13	90508-28015	SPRING, TORSION	1	1	1	1	
14	90508-28018	SPRING, TORSION	1	1	1	1	
15	1C3-27311-00	STAND, SIDE	1	1	1	1	
16	90201-10032	WASHER, PLATE	2	2	2	2	

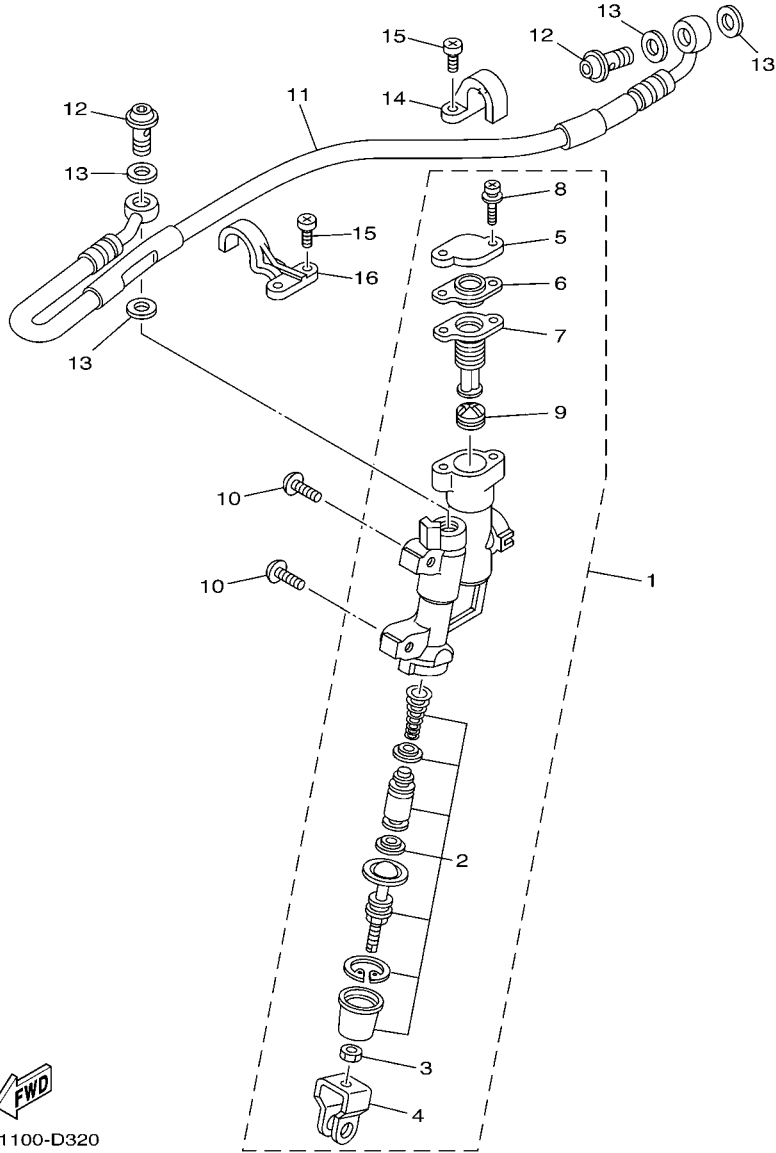

1C31100-D320

FIG. 32 REAR MASTER CYLINDER

REF. NO.	PART NO.	DESCRIPTION	1P85	1P86	1P87	1P88	REMARKS
1	1C3-2583V-00	RR. MASTER CYLINDER ASSY.	1	1	1	1	
2	5UN-W0042-50	.CYLINDER KIT, MASTER	1	1	1	1	
3	5UN-27218-00	.NUT	1	1	1	1	
4	5UN-27222-00	.JOINT	1	1	1	1	
5	5UN-25852-50	.CAP, RESERVOIR	1	1	1	1	
6	5UN-2585B-00	.PLATE, DIAPHRAGM	1	1	1	1	
7	5UN-25854-00	.DIAPHRAGM, RESERVOIR	1	1	1	1	
8	5UN-27217-00	.BOLT	2	2	2	2	
9	5CG-25715-00	.SEPARATOR ASSY	1	1	1	1	
10	90111-06059	BOLT,HEX. SOCKET BUTTON	2	2	2	2	
11	1C3-25873-00	HOSE, BRAKE 2	1	1	1	1	
12	90401-10172	BOLT, UNION	2	2	2	2	
13	90201-10118	WASHER, PLATE	4	4	4	4	
14	1C3-25886-50	HOLDER, BRAKE HOSE	1	1	1	1	
15	98504-05010	SCREW, PAN HEAD	4	4	4	4	
16	1C3-25876-50	HOLDER, BRAKE HOSE 2	1	1	1	1	

FIG. 33 GENERATOR

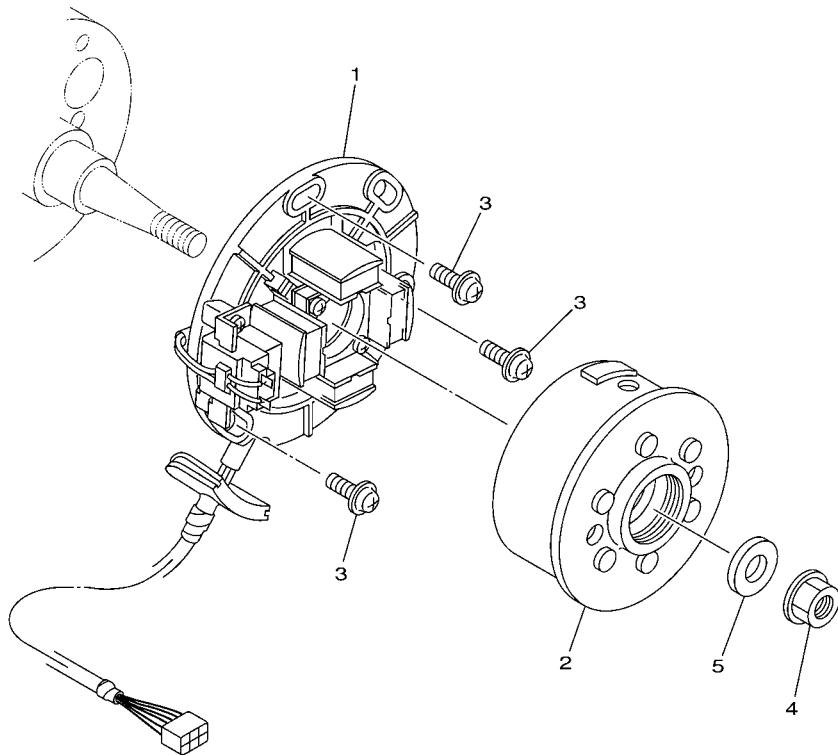

REF. NO.	PART NO.	DESCRIPTION	1P85	1P86	1P87	1P88	REMARKS
1	5CU-85560-20	BASE ASSY	1	1	1	1	
2	5UP-85550-00	ROTOR ASSY	1	1	1	1	
3	90149-06011	SCREW	3	3	3	3	
4	90179-12248	NUT	1	1	1	1	
5	90201-12688	WASHER, PLATE	1	1	1	1	

 5NX1100-A330

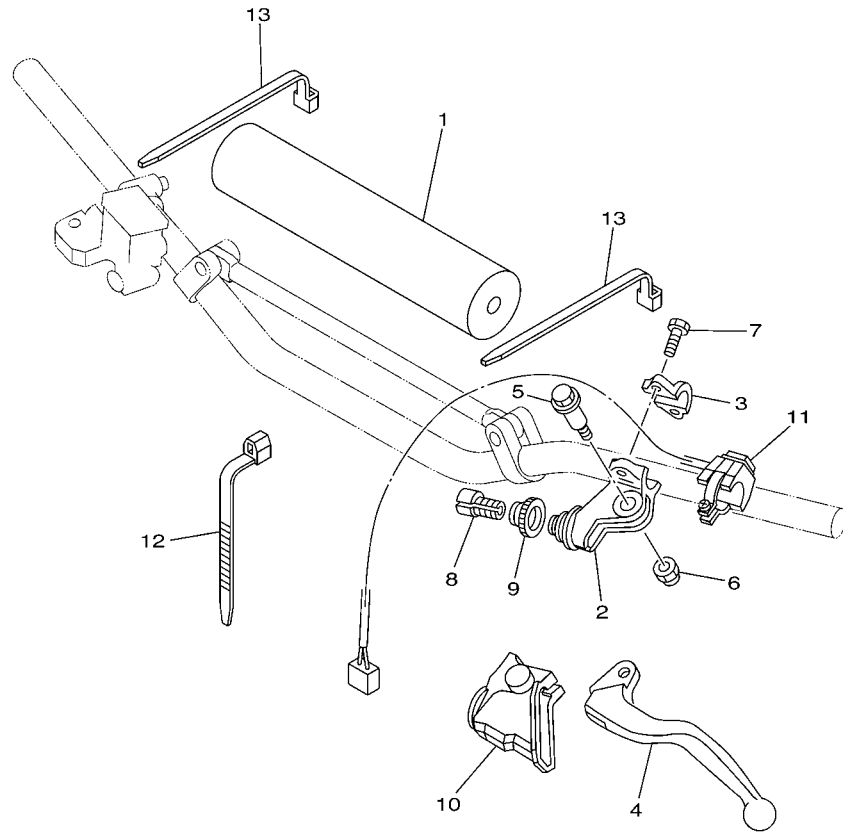
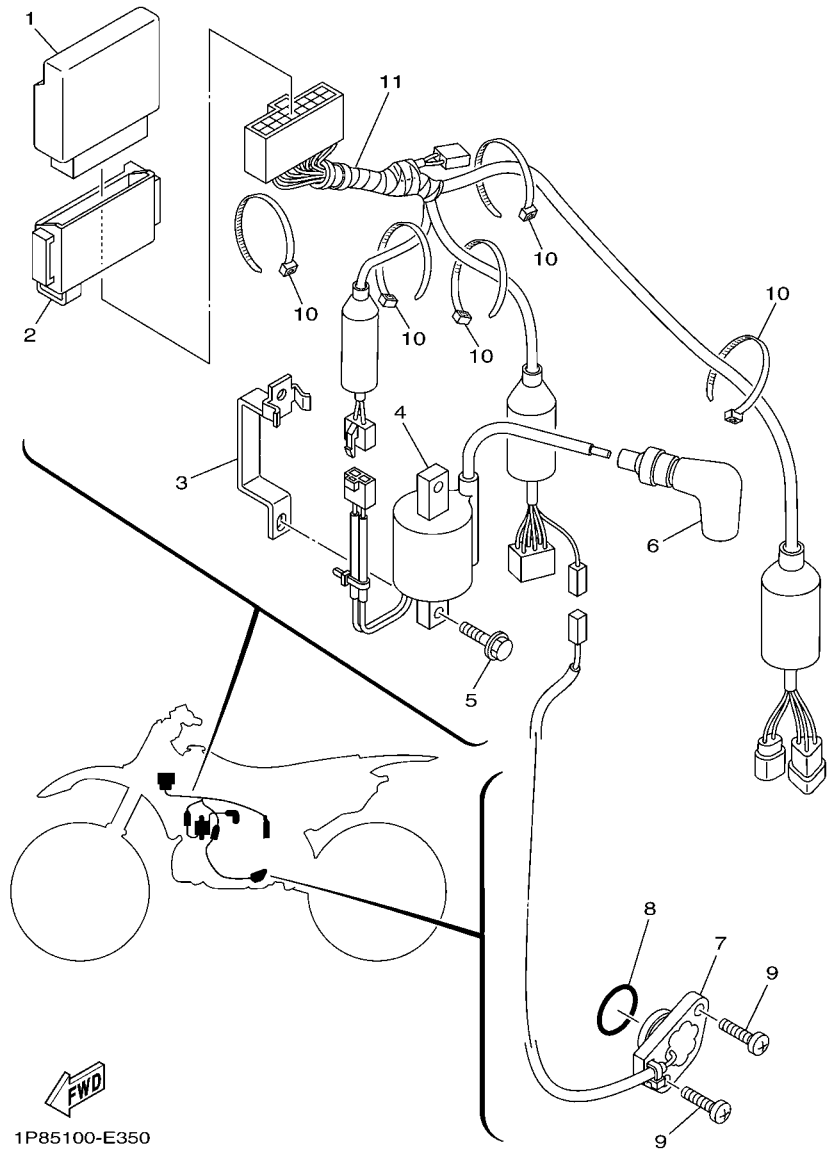

FIG. 34 HANDLE SWITCH & LEVER

REF. NO.	PART NO.	DESCRIPTION	1P85	1P86	1P87	1P88	REMARKS
1	1C3-26124-00	PROTECTOR, HANDLEBAR	1	1	1	1	
2	5XE-82911-00	HOLDER, LEVER 1	1	1	1	1	
3	5TG-82913-00	HOLDER, LEVER LOWER 1	1	1	1	1	
4	5MV-83912-00	LEVER 1	1	1	1	1	
5	90109-06034	BOLT	1	1	1	1	
6	5LP-84126-10	NUT, LENS FITTING	1	1	1	1	
7	90101-05033	BOLT	2	2	2	2	
8	5HD-26337-00	BOLT, ADJUSTING	1	1	1	1	
9	5HD-83951-00	BOLT, CABLE ADJUSTING	1	1	1	1	
10	5HD-26372-00	COVER, HANDLE LEVER 1	1	1	1	1	
11	1C3-83976-00	SWITCH, HANDLE 1	1	1	1	1	
12	90464-13077	CLAMP	3	3	3	3	
13	90464-15195	CLAMP	2	2	2	2	



1C31100-D340



1P85100-E350

FIG. 35 ELECTRICAL 1

REF. NO.	PART NO.	DESCRIPTION	1P85	1P86	1P87	1P88	REMARKS
1	1P8-85540-00	C.D.I. UNIT ASSY	1	1	1	1	
2	1P8-85546-00	BAND	1	1	1	1	
3	1P8-8231U-10	CORE, SIDE	1	1	1	1	
4	1P8-82310-00	IGNITION COIL ASSY	1	1	1	1	
5	95027-06020	BOLT, FLANGE	2	2	2	2	
6	8DG-82370-00	PLUG CAP ASSY	1	1	1	1	
7	1P8-82540-00	NEUTRAL SWITCH ASSY		1	1	1	
8	93210-21276	O-RING		1	1	1	
9	90154-05022	SCREW, BINDING		2	2	2	
10	90465-13275	CLAMP	5	5	5	5	
11	1P8-82509-10	WIRE, SUB LEAD	1				
	1P8-82509-20	WIRE, SUB LEAD		1	1	1	

FIG. 36 ALTERNATE FOR CHASSIS

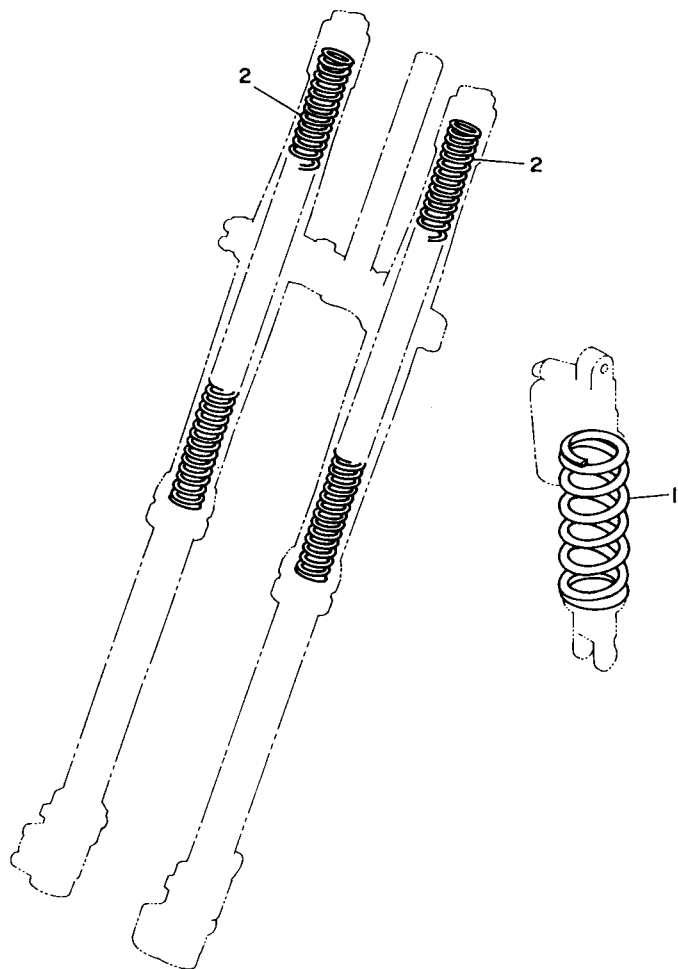

3JD1010-9360

REF. NO.	PART NO.	DESCRIPTION	1P85	1P86	1P87	1P88	REMARKS
1	5UN-22212-00	SPRING (K=42N/MM)	1	1	1	1	AP
	1C3-22212-00	SPRING (K=44N/MM)	1	1	1	1	AP
	1C3-22212-10	SPRING (K=46N/MM)	1	1	1	1	AP
	1C3-22212-30	SPRING (K=50N/MM)	1	1	1	1	AP
	5UN-22212-50	SPRING (K=52N/MM)	1	1	1	1	AP
	5UN-22212-60	SPRING (K=54N/MM)	1	1	1	1	AP
	5UN-22212-70	SPRING (K=56N/MM)	1	1	1	1	AP
	5UN-22212-A0	SPRING (K=APPROX.44N/MM)	1	1	1	1	AP
	5UN-22212-B0	SPRING (K=APPROX.46N/MM)	1	1	1	1	AP
	5UN-22212-C0	SPRING (K=APPROX.48N/MM)	1	1	1	1	AP
	5UN-22212-D0	SPRING (K=APPROX.50N/MM)	1	1	1	1	AP
	5UN-22212-E0	SPRING (K=APPROX.52N/MM)	1	1	1	1	AP
	5UN-22212-F0	SPRING (K=APPROX.54N/MM)	1	1	1	1	AP
	5UN-22212-G0	SPRING (K=APPROX.56N/MM)	1	1	1	1	AP
2	1C3-23141-A0	SPRING, FRONT FORK(K=3.9N/MM)	2	2	2	2	AP
	1C3-23141-B0	SPRING, FRONT FORK(K=4.0N/MM)	2	2	2	2	AP
	1C3-23141-C0	SPRING, FRONT FORK(K=4.1N/MM)	2	2	2	2	AP
	1C3-23141-E0	SPRING, FRONT FORK(K=4.3N/MM)	2	2	2	2	AP
	1C3-23141-F0	SPRING, FRONT FORK(K=4.4N/MM)	2	2	2	2	AP
	1C3-23141-G0	SPRING, FRONT FORK(K=4.5N/MM)	2	2	2	2	AP
	1C3-23141-H0	SPRING, FRONT FORK(K=4.6N/MM)	2	2	2	2	AP
	1C3-23141-J0	SPRING, FRONT FORK(K=4.7N/MM)	2	2	2	2	AP

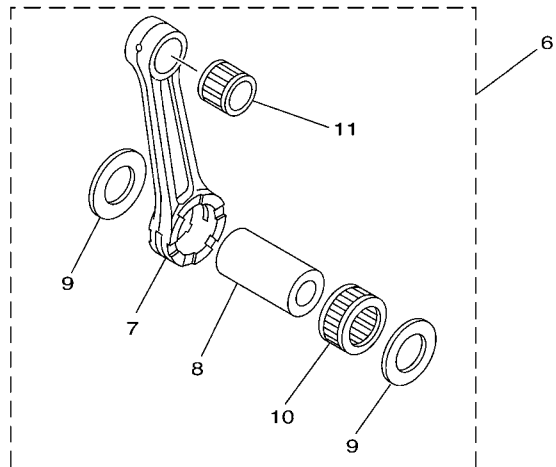
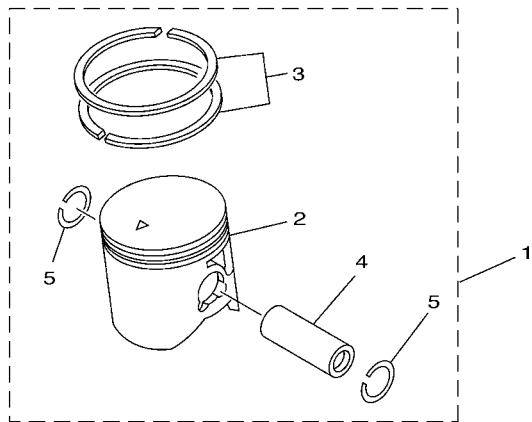

FIG. 37 OPTIONAL PARTS 1

REF. NO.	PART NO.	DESCRIPTION	1P85	1P86	1P87	1P88	REMARKS
1	1P8-11630-00	PISTON ASSY (STD)	1	1	1	1	
2	1P8-11631-00-B0	.PISTON (STD)	1	1	1	1	ORANGE
3	5CU-11603-10	.PISTON RING SET (STD)	1	1	1	1	
4	5UP-11633-00	.PIN, PISTON	1	1	1	1	
5	93450-19052	.CIRCLIP	2	2	2	2	
6	5MW-11650-00	CONNECTING ROD ASSY	1	1	1	1	
7	5MW-11651-00	.ROD, CONNECTING	1	1	1	1	
8	5CU-11681-00	.PIN, CRANK 1	1	1	1	1	
9	90209-24327	.WASHER	2	2	2	2	
10	93310-52406	.BEARING	1	1	1	1	
11	93310-218A6	.BEARING	1	1	1	1	



5MW1100-1370

NUMERICAL INDEX

PART NO.	GRID NO.	PART NO.	GRID NO.	PART NO.	GRID NO.	PART NO.	GRID NO.	PART NO.	GRID NO.	PART NO.	GRID NO.
5UP-11111-00	B - 2	5MW-12422-00	B - 6	4XM-14451-00	B - 8	4MX-14948-06	B - 9	5NX-16371-00	C - 4	4ES-2153E-01	C - 12
5MW-11111-01	B - 2	5XF-12428-00	B - 6	5NX-14453-00	B - 8	4MX-14948-07	B - 9	5CU-16380-10	C - 4	5PA-21568-00	C - 12
5UP-11311-01	B - 2	5DJ-12451-00	B - 6	5NY-14455-10	B - 8	4MX-14948-08	B - 9	5JG-17121-10	C - 6	5XE-21610-10	C - 12
5XF-1131D-00	B - 2	5CU-12459-00	B - 6	3JD-14458-01	B - 8	4MX-14948-09	B - 9	5CU-17131-01	C - 6	5XE-21635-10	C - 12
5CU-1131E-01	B - 2	5NY-12461-00	B - 7	5NY-14459-00	B - 8	4MX-14948-10	B - 9	5BE-17141-30	C - 6	1P8-2163G-00	C - 12
5CU-1131M-10	B - 3	22W-12462-00	B - 7	676-14548-00	B - 10	4MX-14948-11	B - 9	5BE-17151-00	C - 6	5UN-21642-10	C - 12
5CU-1131P-00	B - 2	1C3-12465-00	B - 7	4MX-14561-00	B - 9	4MX-14948-12	B - 9	5BE-17211-00	C - 6	3RV-21668-A0	D - 2
5CU-1131U-10	B - 2	5CU-12481-10	B - 7	5NX-14562-00	B - 11	4JT-1494F-03	B - 11	5JG-17221-10	C - 6	3RV-21668-B0	D - 2
5CU-1131V-00	B - 3	5NY-12482-00	B - 7	1P8-14610-00	B - 13	4JT-1494F-07	B - 11	5BE-17231-00	C - 6	5NY-21711-00	C - 14
5CU-1132A-00	B - 2	1P8-12484-00	B - 7	1P8-14610-10	B - 13	4JT-1494F-09	B - 11	5JG-17241-00	C - 6	5GJ-21717-00	C - 10
5MW-1132E-00	B - 3	353-13115-01	B - 3	3JE-14615-01	B - 13	4JT-1494F-11	B - 11	5BE-17251-10	C - 6	5NY-21721-00	C - 14
5MW-1132F-00	B - 3		B - 15	5MW-14642-00	B - 13	4JT-1494F-13	B - 11	5BE-17402-00	C - 6	1C3-21721-50	C - 14
5UP-11351-00	B - 2	5NX-13565-00	B - 8	1P8-1469A-00	B - 13	4JT-14984-00	B - 9	5BE-17411-00	C - 6	5NL-2172A-20	C - 14
5CU-11354-00	B - 3	5NX-13610-00	B - 8	5HC-1469A-10	B - 13	4SR-14985-00	B - 9	5HC-17466-00	C - 2	5XE-21730-00	C - 14
5NX-11395-00	B - 3	5NX-13613-00	B - 8	1P8-1469E-00	B - 13	1P8-15111-00	B - 15	4L0-17471-00	B - 15	1C3-2173E-10	C - 14
5UP-11400-00	B - 5	4XL-13616-00	B - 8	1P8-14753-00	B - 13	5NX-15111-01	B - 15	5CU-18101-10	C - 9	1C3-2173F-10	C - 14
5UP-11410-00	B - 5	5XF-13622-00	B - 8	5NX-14753-11	B - 13	4V4-15118-00	B - 15	1C3-18110-00	C - 9	5XE-21740-00	C - 14
5MW-11420-00	B - 5	5NX-13624-00	B - 8	5CU-14771-01	B - 13	5CU-15118-10	B - 15	5MW-18122-01	C - 9	1C3-22110-50	C - 15
5CU-11603-10	B - 5	4XL-13625-00	B - 8	5XF-14781-00	B - 13	5NX-15121-00	B - 15	4BR-18127-10	C - 8	1C3-22121-00	D - 2
	E - 11	1P8-14101-30	B - 9	4SR-14916-CJ	B - 10	3Y1-15363-00	C - 2	5CU-18140-01	C - 8	1C3-22122-00	D - 2
1P8-11630-00	E - 11	1P8-14101-40	B - 9	4SR-14916-CK	B - 9	4JT-15381-01	B - 15	5CU-18172-00	C - 9	1C3-22128-00	C - 15
1P8-11631-00-A0	B - 5	1P8-14101-50	B - 9	4SR-14916-CW	B - 10	5CU-15411-10	C - 2	3XJ-18173-10	C - 9	1C3-22141-10	C - 15
1P8-11631-00-B0	B - 5	4SR-14105-00	B - 10	4SR-14916-EH	B - 10	5MW-15415-10	C - 2	3XJ-18178-00	C - 9	1C3-22151-00	C - 15
	E - 11	4XL-1410E-00	B - 11	4SR-14916-EJ	B - 9	1P8-15421-10	C - 2	3XJ-18182-00	C - 9	5UN-22176-00	D - 3
1P8-11631-00-C0	B - 5	5NX-1410H-10	B - 11	4SR-14916-EK	B - 9	5NX-15431-00	C - 2	3XJ-18184-00	C - 9	30X-22178-00	C - 10
1P8-11631-00-D0	B - 5	4MX-14115-00	B - 9	4SR-14916-EW	B - 9	5CU-15451-00	C - 2	4EW-18185-00	C - 8	3JD-22178-20	C - 10
5UP-11633-00	B - 5	5HC-14126-00	B - 10	4SR-14916-FH	B - 10	5CU-15454-00	B - 15	5BE-18501-20	C - 8	1C3-2217A-00	C - 15
	E - 11	5HC-14131-00	B - 10	4SR-14916-RJ	B - 10	5CU-15462-00	C - 2	5BE-18502-20	C - 8	1C3-2217F-50	C - 15
5MW-11650-00	E - 11	3TJ-14137-40	B - 10	4SR-14916-RW	B - 10	5CU-15463-00	C - 2	5CU-18503-20	C - 8	4V4-22184-00	C - 10
5MW-11651-00	B - 5	4XL-14146-00	B - 9	4MX-14919-00	B - 10	5NX-15601-10	C - 3	1P8-18541-00	C - 8	5MV-22184-00	D - 3
	E - 11	5HC-14146-00	B - 11	5HC-14922-00	B - 11	5NX-15620-11	C - 3	4UN-18542-00	C - 8	1C3-22199-10	C - 15
5CU-11681-00	B - 5	4JT-14147-00	B - 11	5HC-14934-00	B - 11	5NX-15621-10	C - 3	5DH-18562-00	C - 8	1P8-22200-50	D - 3
	E - 11	663-14159-00	B - 10	4MX-14943-40	B - 10	5CU-15651-00	C - 3	1P8-21101-50	C - 10	1P8-22200-60	D - 3
5CU-11830-00	B - 3	4JT-14171-00	B - 9	4MX-14943-41	B - 10	5NL-15664-00	C - 3	5PA-2118K-00	C - 12	1P8-22200-70	D - 3
4SS-11832-00	B - 3	4MX-14194-00	B - 11	4MX-14943-42	B - 11	4GY-15671-00	C - 3	5PA-2118K-10	C - 13	1P8-22200-80	D - 3
5CU-11911-00	B - 4	4XL-14196-10	B - 10	4MX-14943-43	B - 10	214-15674-00	C - 3	5PA-2118K-20	C - 12	1P8-22200-90	D - 3
5CU-11912-00	B - 4	4XL-14197-10	B - 10	4MX-14943-44	B - 11	214-15686-00	C - 3	1C3-21190-50	C - 10	1P8-22201-50	D - 3
4JY-11915-10	B - 4	1P8-14208-00	B - 11	4MX-14943-45	B - 11	5DJ-16111-00	C - 4	1C3-21244-10	C - 11	1P8-22201-60	D - 3
5X4-11921-02	B - 4	5HC-14216-00	B - 11	4MX-14943-90	B - 10	5MW-16113-00	C - 4	1C3-2135F-00	D - 2	1P8-22201-70	D - 3
3JE-11922-01	B - 4	5NX-14216-00	B - 12	4MX-14943-91	B - 10	5DJ-16150-00	C - 4	1C3-2139R-00	D - 2	1P8-22201-80	D - 3
5CU-11952-00	B - 4	5HC-14261-00	B - 10	4MX-14943-92	B - 10	2K7-16154-00	C - 4	5NX-21425-00	C - 10	1P8-22201-90	D - 3
5NY-11953-00	B - 4	5HC-14264-00	B - 11	4MX-14943-93	B - 10	5CU-16154-00	C - 4	1C3-21447-10	C - 10	1C3-22212-00	E - 10
5CU-11956-00	C - 4	5HC-14275-00	B - 11	4MX-14943-94	B - 11	2VM-16181-00	C - 4	1C3-21448-10	C - 10	5UN-22212-00	E - 10
5CU-11990-10	B - 4	5HC-14340-A7	B - 10	4MX-14943-95	B - 11	3XK-16321-00	C - 4	1C3-21511-50	C - 12	1C3-22212-10	E - 10
5CU-11991-00	B - 3	4MX-14392-00	B - 9	4MX-14948-02	B - 9	4X7-16325-00	C - 4	4LB-2151H-02	C - 12	1C3-22212-20	D - 3
5CU-11993-00	B - 3	5NY-14401-01	B - 8	4MX-14948-03	B - 9	5JG-16351-00	C - 4	3XJ-2151H-A1	C - 12	1C3-22212-30	E - 10
5CU-11995-00	B - 3	5NY-14417-00	B - 8	4MX-14948-04	B - 9	4XL-16356-00	C - 4	3XJ-2151H-B1	C - 13	5UN-22212-50	E - 10
5NX-1240A-00	B - 7	5NY-14442-00	B - 8	4MX-14948-05	B - 9	1P8-16357-00	C - 4	4XL-2153A-10	D - 8	5UN-22212-60	E - 10

NUMERICAL INDEX

PART NO.	GRID NO.	PART NO.	GRID NO.	PART NO.	GRID NO.	PART NO.	GRID NO.	PART NO.	GRID NO.	PART NO.	GRID NO.
5UN-22212-70	E - 10	5XE-23144-L0	D - 6	1C3-24240-10	D - 9	5UN-2585B-00	E - 6	1C3-27311-00	E - 5	90105-10079	C - 11
5UN-22212-A0	E - 10	1C3-23145-M0	D - 6	3XJ-24380-00	D - 9	5MV-25867-00	E - 4	5XE-27411-01	E - 5	90105-10445	C - 4
5UN-22212-B0	E - 10	5XE-23146-L0	D - 6	3JD-24500-10	D - 9	5NY-25868-00	E - 4	5XE-27421-01	E - 5	90105-10733	C - 10
5UN-22212-C0	E - 10	1AE-23147-00	D - 6	4X8-24512-00	D - 9	1C3-25872-50	E - 4	1C3-27491-50	E - 2	90109-05001	B - 2
5UN-22212-D0	E - 10	1C3-23147-L0	D - 6	3AJ-24534-01	D - 9	1C3-25873-00	E - 6	5ET-28166-10	C - 11	90109-056G0	C - 4
5UN-22212-E0	E - 10	1C3-2314F-M0	D - 6	5NY-24610-00	D - 9	1C3-25875-50	D - 13	1P8-82310-00	E - 9	90109-06034	E - 8
5UN-22212-F0	E - 10	1C3-2314H-10	D - 8	1C3-2470F-50	D - 11	1C3-25876-50	E - 6	1P8-8231U-10	E - 9	90109-065G4	E - 2
5UN-22212-G0	E - 10	1C3-2314J-10	D - 8	5NY-24728-10	D - 11	1C3-25886-50	E - 6	8DG-82370-00	E - 9	90109-066G1	C - 8
3SP-22213-00	D - 3	5XE-23153-L0	D - 6	1C3-24770-50	D - 11	5MV-2589F-00	E - 4	1P8-82509-10	E - 9	90109-067F4	B - 8
1C3-22214-50	D - 3	2HH-23158-L0	D - 6	5NY-25104-00	D - 12	5UN-25914-00	E - 2	1P8-82509-20	E - 9	90109-08078	D - 14
5MV-22224-00	D - 3	1P8-2316A-M0	D - 6	5NY-25111-00	D - 12	5DH-25914-50	E - 2	1P8-82540-00	E - 9	90110-08052	C - 3
4JX-22226-00	D - 3	1C3-2316A-N0	D - 6	5NY-25117-00	D - 12	3SP-25914-51	D - 13	5XE-82911-00	E - 8	90111-06059	E - 6
3SP-22234-00	D - 3	1P8-23170-L0	D - 6	1C3-25181-10	D - 12	5DH-25916-00	D - 13	5TG-82913-00	E - 8	90116-08394	B - 2
5NY-22241-00	D - 4	1C3-23170-N0	D - 6	5NY-25183-00	D - 12		E - 2	5MV-83912-00	E - 8	90116-10314	B - 2
5XE-22242-00	D - 4	5XE-23171-L0	D - 6	5NY-25186-00	D - 12	3JD-25917-00	D - 13	5MV-83922-00	E - 4	90119-06096	C - 12
5MV-22253-00	D - 4	5DH-23183-00	D - 3	5HD-25304-00	D - 14		E - 2	5HD-83951-00	E - 8	90119-06133	B - 13
1C3-22253-50	D - 3	509-23184-L0	D - 3	5TJ-2530S-80	D - 15	5DH-25919-00	D - 13	1C3-83976-00	E - 8	90119-06217	D - 5
4AA-22259-40	D - 3	1C3-23188-L0	D - 6	5ET-25311-00	D - 14	5DH-25919-50	E - 2	5LP-84126-10	E - 8	90119-06225	C - 12
4AA-22259-50	D - 3	1C3-23188-N0	D - 6	5ET-25317-00	D - 14	8CR-25924-00	E - 2	1P8-85540-00	E - 9	90119-08086	C - 14
4AA-22259-60	D - 3	1C3-23188-P0	D - 6	4XM-25364-00	D - 14	3SP-25926-51	D - 13	1P8-85546-00	E - 9	90122-06005	B - 8
4AA-22259-80	D - 3	1C3-23188-R0	D - 6	1C3-25381-10	D - 15	5DH-25933-00	D - 13	5UP-85550-00	E - 7	90149-06011	D - 9
1P8-22355-00	C - 15	1C3-23190-L0	D - 6	1C3-25388-50	D - 15	1UY-25937-51	D - 13	5CU-85560-20	E - 7		E - 7
4EW-22474-00	D - 3	5TJ-2319U-00	D - 5	1C3-25389-00	D - 15		E - 2	5NX-85885-10	B - 11	90149-06326	B - 15
3JE-22475-00	D - 3	1P8-23340-M0	D - 8	3JE-25394-00	D - 14	1C3-26111-00	E - 3	5NY-W0041-00	E - 4	90149-06327	D - 13
5NY-22475-00	D - 4	3SP-23356-L0	D - 8	5SF-25394-00	D - 12	1C3-26124-00	E - 8	5UN-W0042-50	E - 6	90149-10031	C - 10
1C3-22565-00	D - 4	5XE-23389-00	D - 8	1C3-25447-00	D - 14	4XM-26240-00	E - 3	5MV-W0045-01	D - 13	90151-04001	C - 15
5UN-22898-60	E - 2	4EW-23416-00	D - 5	1C3-25448-00	D - 14	4GY-26241-00	E - 3	1C3-W0046-10	E - 2	90152-06010	C - 3
1C3-22969-50	C - 15	1C3-23435-50	D - 5	1C3-25449-00	D - 14	4GY-26242-00	E - 3	3JD-W0047-00	D - 13	90154-05022	E - 9
1P8-23102-50	D - 6	1C3-23441-50	D - 5	1C3-25450-00	D - 14	4XM-26243-00	E - 3	5UN-W0047-50	E - 2	90157-06077	B - 15
1P8-23102-60	D - 6	1C3-23442-50	D - 5	1C3-25451-00	D - 14	4SS-26256-00	E - 3	1UY-W0048-50	D - 13	90159-06010	C - 4
1P8-23103-50	D - 7	1C3-23466-50	D - 13	1C3-25452-00	D - 14	4SS-26259-00	E - 3		E - 2	90159-06021	C - 14
1P8-23103-60	D - 7	1C3-23467-50	D - 13	5CG-25715-00	E - 4	5NY-26273-00	E - 3	5UN-W0057-00	D - 13	90170-20255	C - 4
1C3-23110-M0	D - 7	1C3-23485-50	D - 5		E - 6	4SS-26281-00	E - 3	5UN-W0057-50	E - 2	90170-24003	D - 5
1C3-23111-L0	D - 6	1C3-24110-50	D - 9	1C3-25718-50	E - 2	4SS-26282-10	E - 3	5XE-W2587-00	E - 4	90176-08026	B - 2
276-23114-00	D - 6	4EW-2412F-00	D - 9	1C3-2580T-00	D - 13	4SS-26287-01	E - 3	90101-05033	E - 8	90179-06028	C - 15
1C3-23120-M0	D - 6	5XE-24144-00	D - 9	1C3-2580W-60	E - 2	4SS-2628H-00	E - 3	90101-06041	C - 9	90179-08656	D - 15
5XE-23125-L0	D - 6	3ME-2415E-01	C - 12	5MV-2581T-00	D - 13	1P8-26311-50	E - 3	90101-08006	D - 15	90179-08674	C - 10
1C3-23136-M0	D - 6	3XJ-2415E-A0	C - 12	5UN-25827-60	E - 2	4SS-2632G-00	E - 3	90105-05002	B - 4	90179-10658	C - 10
1C3-23141-A0	E - 10	3XJ-2415E-B0	C - 12	5UN-25828-60	E - 2	1P8-26335-50	E - 3	90105-06062	C - 12	90179-10M35	B - 2
1C3-23141-B0	E - 10	3XJ-2415E-C0	C - 12	5NY-2582W-00	E - 2	5HD-26337-00	E - 8	90105-06063	C - 12	90179-12248	E - 7
1C3-23141-C0	E - 10	4SR-2416E-00	C - 12	5MV-25833-00	E - 4	1C3-26342-50	E - 3	90105-06064	C - 14	90179-16003	D - 12
1C3-23141-E0	E - 10	3SP-24173-00	D - 9	1C3-2583V-00	E - 6	5HD-26372-00	E - 8	90105-06085	B - 15	90179-20255	C - 7
1C3-23141-F0	E - 10	5XE-24176-00	D - 9	5DH-25849-00	D - 13	5NY-26372-00	E - 4	90105-06553	C - 8	90179-28003	D - 5
1C3-23141-G0	E - 10	1C3-24181-00	D - 9	5MV-25852-01	E - 4	1C3-27200-10	E - 5	90105-08059	C - 10	90183-06023	B - 8
1C3-23141-H0	E - 10	1P8-24182-00	D - 9	5UN-25852-50	E - 6	5UN-27217-00	E - 6	90105-08077	D - 13	90185-08008	D - 14
1C3-23141-J0	E - 10	1C3-24183-00	D - 9	5XE-25853-00	E - 4	1C3-27217-10	E - 5	90105-08085	C - 10	90185-08009	C - 10
1P8-23141-M0	D - 6	1C3-24184-00	D - 10	5UN-25854-00	E - 6	5UN-27218-00	E - 6	90105-08120	C - 10	90185-10060	D - 4
1C3-23142-L0	D - 6	5NY-24186-00	D - 9	5XE-25854-00	E - 4	5UN-27222-00	E - 6	90105-10074	C - 10	90185-14007	D - 2

NUMERICAL INDEX

PART NO.	GRID NO.	PART NO.	GRID NO.	PART NO.	GRID NO.	PART NO.	GRID NO.	PART NO.	GRID NO.	PART NO.	GRID NO.
90185-16002	C - 15	90209-24327	E - 11	90464-13077	E - 8	93102-12224	C - 9	93340-21505	C - 4	95024-08040	D - 5
90185-20002	D - 15	90209-26348	C - 6	90464-15195	E - 8	93102-18278	C - 3	93342-22217	C - 15		D - 8
90201-03313	B - 8	90215-20231	C - 4	90465-13275	D - 9	93102-20485	B - 5	93410-20038	C - 3	95024-08055	C - 10
90201-057H5	B - 2	90215-21256	C - 7		E - 9	93102-26468	D - 12	93440-10085	C - 4	95027-06010	C - 2
	B - 4	90240-08120	E - 5	90467-090A2	B - 7	93102-28004	B - 5	93440-25084	C - 6	95027-06016	D - 9
90201-06013	C - 8	90240-10004	E - 5	90467-100A1	D - 9	93102-32337	C - 6	93440-28062	C - 6	95027-06020	C - 9
90201-06032	C - 12	90267-32070	B - 8	90468-16001	E - 5	93104-08040	B - 3	93450-19052	B - 5		E - 9
90201-06033	B - 13	90280-03017	B - 5	90480-08608	D - 15		B - 4		E - 11	95027-06025	B - 6
	C - 12	90340-12006	B - 15	90480-15528	B - 7	93106-22002	C - 15	93507-16020	B - 4		C - 2
90201-060A3	B - 14	90387-06009	C - 12	90480-16404	B - 14	93106-30001	D - 14	93507-32009	C - 3		E - 3
90201-06557	C - 12	90387-06039	B - 14	90480-16561	B - 13	93106-30045	D - 14	93603-14240	B - 4	95027-06030	B - 7
90201-06571	B - 7	90387-06065	B - 7	90480-17004	B - 13	93109-11073	B - 6	93604-08071	B - 2		C - 2
90201-08043	C - 10	90387-06090	C - 12	90480-18549	D - 9	93109-21001	D - 2	93604-10011	B - 6	95027-06050	C - 2
90201-08044	E - 5	90387-06104	D - 8	90501-046L6	B - 3	93109-25001	C - 15	93604-29184	B - 4	95027-06065	B - 6
90201-08045	C - 10	90387-06121	B - 13	90501-052G5	C - 9	93109-28043	C - 15	93612-16254	B - 15		C - 2
90201-08048	C - 3	90387-063G3	B - 13	90501-06022	C - 8	93210-06001	E - 3	9383E-13216	C - 7	95602-12200	D - 5
	D - 15	90387-08030	B - 13	90501-147A5	C - 3	93210-11073	E - 5	9383E-14215	C - 7	95607-10200	D - 4
90201-08049	B - 13	90387-08041	C - 10	90501-16016	C - 3	93210-15639	B - 2	94108-21012	D - 12	95617-10660	B - 2
90201-080L8	B - 2	90387-085E1	B - 4	90501-237L0	C - 4	93210-17570	C - 3	94108-21015	D - 12	95701-06500	E - 4
90201-081G0	B - 3	90387-086N4	C - 10	90501-256L2	B - 4	93210-19123	C - 2	94108-2112Y	D - 12	95702-06500	D - 13
90201-08512	B - 6	90387-124F4	C - 9	90506-16007	E - 5	93210-21276	E - 9	94111-19011	D - 14	95822-06010	B - 7
90201-08730	C - 10	90387-14005	D - 2	90507-14064	C - 8	93210-22298	C - 6	94111-19015	D - 14	95824-06016	C - 14
90201-08784	B - 6	90387-152F2	B - 4	90507-20052	B - 13	93210-74316	B - 2	94111-1913A	D - 14	97007-05020	B - 3
90201-10032	E - 5	90387-16010	C - 15	90508-155B8	B - 3	93211-02703	B - 2	94209-21229	D - 12	97027-06016	C - 3
90201-10118	E - 4	90387-18004	C - 15	90508-28015	E - 5	93300-60801	B - 4	94211-19273	D - 14	97307-06012	D - 11
	E - 6	90387-18007	B - 15	90508-28018	E - 5	93300-60839	C - 10	94211-19274	D - 14	97707-60016	C - 12
90201-105P3	C - 4	90387-18011	C - 15	90508-291A8	C - 9	93306-00105	B - 6	94227-21101	D - 12	98502-04012	B - 11
90201-12028	D - 5	90387-2113G	C - 6	90508-30743	C - 3	93306-00426	C - 6	94309-21161	D - 12	98502-04014	B - 10
90201-12575	C - 9	90387-227H7	E - 3	91317-04006	B - 4	93306-00442	C - 6	94311-19155	D - 14	98504-05010	E - 6
90201-125L6	C - 4	90387-2515B	C - 6	91317-04008	B - 3	93306-07202	D - 14	94321-19157	D - 14	98507-03008	B - 8
90201-12688	E - 7	90401-10172	E - 4	91317-06012	B - 15	93306-20540	C - 6	94330-21084	D - 12		D - 9
90201-14740	D - 2		E - 6	91317-06025	B - 8	93306-20574	C - 6	94416-21018	D - 12	98507-05012	B - 2
90201-150U6	B - 4	90430-05242	C - 5	91317-06050	B - 15	93306-27212	D - 14	94421-19003	D - 14	98507-06030	C - 2
90201-16018	C - 15	90430-06014	B - 6	91317-06060	B - 15	93306-37808	B - 5	94681-68001	D - 15	98580-04006	B - 11
90201-162H4	C - 3		C - 2	91317-06070	B - 15	93306-90409	D - 12	94702-00326	B - 2	98706-04012	E - 4
90201-167P7	C - 3	90430-12227	B - 15	91402-20012	E - 5	93306-90501	C - 8	94709-00326	B - 2	98707-06025	D - 9
90201-20020	D - 15	90445-08376	B - 15	91402-25015	E - 5	93306-90506	C - 8	95022-06012	E - 2	98902-05012	B - 3
90201-20276	C - 3	90445-09025	D - 9	91A20-05065	B - 7	93310-218A6	B - 5	95022-06025	B - 13		B - 4
90201-20685	C - 3	90445-09220	D - 9	92012-06010	B - 13		E - 11	95022-06030	B - 14	98907-05016	B - 3
90201-21014	C - 15	90445-09777	B - 3	92017-06010	B - 13	93310-230T7	C - 4	95022-08035	B - 13	98907-06025	D - 9
90201-24016	D - 5	90445-111J0	D - 9	92907-03100	B - 8	93310-52406	B - 5	95022-08040	C - 10	99001-06600	B - 6
90201-253K0	C - 6	90450-25001	B - 7	92907-05600	B - 3		E - 11	95024-06010	C - 15	99009-16400	C - 3
90201-286K9	D - 5	90450-28001	B - 7	92907-06100	D - 11	93315-11206	C - 4		D - 13	99009-20400	C - 3
90202-05193	D - 9	90450-51070	B - 8	92907-06600	C - 2	93315-32166	C - 15	95024-06016	E - 2	99009-45500	D - 14
90209-06096	B - 8	90450-70072	B - 8	92907-10200	C - 10	93317-22262	C - 15	95024-06020	D - 8	99530-08016	C - 2
90209-16011	C - 15	90462-08040	B - 15		D - 4	93332-00068	D - 5	95024-06030	E - 2	99590-14016	B - 2
90209-21332	C - 6	90462-08041	B - 15	93102-12106	B - 6	93332-00081	D - 8	95024-06050	C - 15	9Y581-92113	D - 15
90209-24327	B - 5	90464-06214	B - 8	93102-12224	C - 4	93340-21505	B - 4	95024-08035	D - 5		